



## Inventario de ejercicios, problemas y actividades de Matemática (tercer grado de secundaria) (Apoyo a la recuperación académica 2017)

Estimado estudiante:

Te proponemos el presente inventario de ejercicios y problemas (actividades para otras áreas) como un recurso de apoyo para el proceso de recuperación académica que debes seguir durante el mes de enero de 2018. Te pedimos tener presente que:

- El inventario ha sido elaborado de acuerdo con el temario de la evaluación de salida del cuarto bimestre.
- Los ejercicios y problemas que se presenta en el inventario han sido tomados de:
  - los documentos de trabajo del año escolar 2017
  - otras fuentes, pero que se ajustan a los contenidos del temario.
- El inventario ha sido dosificado para ser desarrollado en cuatro semanas, de lunes a viernes, destinando para ello una hora diaria aproximadamente.
- El inventario debe ser desarrollado en pliegos de papel oficio cuadriculado. Su presentación será en un folder manila tamaño oficio (incluir carátula), el mismo que será revisado y evaluado por los docentes responsables de la evaluación de recuperación, asignándole un peso de 25 % en el resultado final de la recuperación como "evaluación de portafolio". De hecho, si no presentases el cuaderno con el inventario desarrollado, se te asignará la nota mínima en evaluación de portafolio.
- Si los estudiantes requiriesen presentarse a la segunda oportunidad, podrán mejorar y volver a presentar el inventario desarrollado, prevaleciendo, en este caso, la segunda calificación. Si no lo hiciesen, mantendrán la calificación obtenida en la primera ocasión.
- En la tabla de control diario, el padre de familia debe firmar para apoyar y controlar el avance diario del estudiante en el desarrollo del inventario.
- No hemos incluido una calendarización específica para el desarrollo del inventario (fechas de inicio y fin), asumiendo que cada estudiante lo hará en coordinación con sus padres, considerando la realidad particular y los planes de la familia. En todo caso, el trabajo ha sido previsto para cuatro semanas.
- La primera oportunidad de evaluación será a fines de enero. La presentación del portafolio con el inventario desarrollado es obligatoria desde la primera oportunidad de evaluación.

### Semana 1

**Tema: Técnicas de conteo.**

1. Pepe, Juan, Andrés, Pedro y Roberto son candidatos a los cargos de presidente, secretario y tesorero de su selección de fútbol. Sus compañeros los elegirán por votación marcando un nombre para presidente, otro para secretario y otro para tesorero. ¿De cuántas maneras distintas pueden votar?  
A) 20                      B) 40                      C) 60                      D) 80                      E) 100
2. En una audiencia judicial, el juez, el secretario, el abogado y el reo son los únicos que no pueden cambiar de asientos. ¿Cuántos ordenamientos se pueden realizar al cambiar de asientos el resto de oyentes, si son 12 personas los que están en la sala de audiencias?  
A) 40 200                  B) 40 000                  C) 40 320                  D) 40 300                  E) 40 350
3. Entre Rosa, Ana, Adela, Elizabeth y Ruth se debe elegir una comisión de aniversario integrada por 3 personas. ¿De cuántas formas distintas se podrá elegir la comisión?  
A) 10                      B) 12                      C) 14                      D) 16                      E) 18
4. En una prueba final de natación, cinco nadadores se disputan las preseas de oro, plata y bronce. ¿De cuántas formas diferentes pueden entregarse dichos premios?  
A) 24                      B) 120                      C) 720                      D) 60                      E) 50
5. ¿Cuántas señales distintas de 4 banderas en fila se pueden hacer con 6 banderas diferentes?  
A) 120                      B) 360                      C) 600                      D) 300                      E) 50
6. Siete atletas compiten por los tres primeros puestos. ¿Cuántos resultados distintos pueden darse?  
A) 210                      B) 220                      C) 230                      D) 260                      E) 120

7. En un club se va a elegir una comisión para organizar los juegos deportivos anuales. Si asisten 20 personas, ¿de cuántas maneras se pueden elegir a cinco personas para dicha comisión?
- A) 11 504                      B) 12 504                      C) 13 504                      D) 14 504                      E) 15 504
8. Con los dígitos 1, 2, 3, 4, 5, 6 y 7, ¿cuántos numerales de 4 cifras distintas se pueden escribir?
- A) 840                          B) 860                          C) 880                          D) 900                          E) 920
9. Se reúnen seis personas para formar un comité de tres miembros, ¿cuántos son los posibles comités a formarse?
- A) 18                            B) 20                            C) 22                            D) 24                            E) 26
10. El profesor Humberto tiene tres sortijas distintas. ¿De cuántas maneras puede colocarlos en sus dedos de la mano derecha, colocando sólo una sortija por dedo, sin contar el pulgar?
- A) 12                            B) 16                            C) 20                            D) 24                            E) 28

**Tema: Operaciones con radicales.**

**Efectúa:**

11.  $4\sqrt{300} + \sqrt{192} + \sqrt{243}$
- A.  $57\sqrt{3}$                       B.  $56\sqrt{3}$                       C.  $55\sqrt{3}$                       D.  $54\sqrt{3}$                       E.  $53\sqrt{3}$
12.  $\frac{1}{5}\sqrt{125} + \frac{2}{3}\sqrt{45} - \frac{3}{7}\sqrt{245}$
- A. 4                              B. 3                              C. 2                              D. 1                              E. 0
13.  $\frac{3}{2}\sqrt[3]{24} + \frac{1}{5}\sqrt[3]{375} + \frac{1}{7}\sqrt[3]{1029}$
- A.  $4\sqrt[3]{3}$                       B.  $3\sqrt[3]{3}$                       C.  $2\sqrt[3]{3}$                       D.  $5\sqrt[3]{3}$                       E.  $\sqrt[3]{3}$
14.  $2\sqrt[3]{48} + \sqrt[3]{432} - \sqrt[3]{384}$
- A.  $8\sqrt[3]{2}$                       B.  $3\sqrt[3]{3}$                       C.  $6\sqrt[3]{2}$                       D.  $5\sqrt[3]{2}$                       E.  $2\sqrt[3]{3}$
15.  $\frac{1}{2}\sqrt{6} \cdot \frac{2}{3}\sqrt{5}$
- A.  $\sqrt{11}$                       B.  $\sqrt{10}$                       C.  $\sqrt{13}$                       D.  $\sqrt{2}$                       E.  $\sqrt{5}$

Tabla de respuestas de la semana 1							
1.	C	2.	C	3.	A	4.	D
5.	B	6.	A	7.	E	8.	A
9.	B	10.	D	11.	A	12.	E
13.	D	14.	C	15.	B		

Tabla de firmas del padre de familia de control diario de la semana 1				
	Martes 2 de enero	Miércoles 3 de enero	Jueves 4 de enero	Viernes 5 de enero

## Tema: Operaciones con radicales.

16.  $\frac{2}{3}\sqrt{5} \cdot \frac{3}{4}\sqrt{10} \cdot \frac{1}{2}\sqrt{15}$

A.  $\frac{5}{4}\sqrt{30}$

B.  $\frac{5}{6}\sqrt{30}$

C.  $\frac{3}{4}\sqrt{30}$

D.  $\frac{1}{4}\sqrt{30}$

E.  $\frac{7}{4}\sqrt{30}$

17.  $\frac{5}{6}\sqrt[3]{4} \cdot \frac{1}{5}\sqrt[3]{16} \cdot 6\sqrt[3]{12}$

A.  $3\sqrt[3]{12}$

B.  $4\sqrt[3]{12}$

C.  $4\sqrt[3]{11}$

D.  $2\sqrt[3]{12}$

E.  $4\sqrt[3]{10}$

18.  $5\sqrt{120} \div 6\sqrt{40}$

A.  $\frac{5}{6}\sqrt{2}$

B.  $\frac{1}{6}\sqrt{3}$

C.  $\frac{5}{6}\sqrt{3}$

D.  $\frac{1}{6}\sqrt{2}$

E.  $\frac{5}{6}\sqrt{5}$

19.  $\frac{3}{5}\sqrt{500} \div \frac{3}{2}\sqrt{20}$

A. 5

B. 4

C.  $\sqrt{3}$

D. 3

E. 2

20.  $\frac{7}{8}\sqrt[3]{1024} \div \frac{3}{4}\sqrt[3]{2}$

A.  $\frac{28}{3}$

B.  $\frac{25}{3}$

C.  $\frac{23}{3}$

D.  $\frac{19}{3}$

E.  $\frac{17}{3}$

## Tema: Ecuaciones cuadráticas.

- Simplifica y halla el conjunto solución de:

21.  $(x+5)^2 + (x+3) = 5$

A.  $\left\{\frac{-11 \pm \sqrt{29}}{2}\right\}$

B.  $\left\{\frac{-9 \pm \sqrt{29}}{2}\right\}$

C.  $\left\{\frac{-7 \pm \sqrt{29}}{2}\right\}$

D.  $\left\{\frac{-5 \pm \sqrt{29}}{2}\right\}$

E.  $\left\{\frac{-3 \pm \sqrt{29}}{2}\right\}$

22.  $x^2 + \frac{3}{4}x = \frac{22}{4}$

A.  $\left\{\frac{-3}{4}; 2\right\}$

B.  $\left\{\frac{-1}{4}; 2\right\}$

C.  $\left\{\frac{-11}{4}; 2\right\}$

D.  $\left\{\frac{-13}{4}; 2\right\}$

E.  $\left\{\frac{-7}{4}; 2\right\}$

23.  $\frac{2}{5}(x-5) + \frac{(x-4)}{4} = \frac{x^2-53}{5}$

A.  $\left\{\frac{-3}{4}; 8\right\}$

B.  $\left\{\frac{-1}{4}; 8\right\}$

C.  $\left\{\frac{-11}{4}; 8\right\}$

D.  $\left\{\frac{-13}{4}; 8\right\}$

E.  $\left\{\frac{-19}{4}; 8\right\}$

24.  $(x-7)^2 + (x-6)^2 = x$

A.  $\left\{4; \frac{17}{2}\right\}$

B.  $\left\{5; \frac{17}{2}\right\}$

C.  $\left\{3; \frac{17}{2}\right\}$

D.  $\left\{2; \frac{17}{2}\right\}$

E.  $\left\{1; \frac{17}{2}\right\}$

25.  $(x+1)(x-2) + (x+4)(x-1) = 0$

A.  $\left\{\frac{-1 \pm \sqrt{17}}{2}\right\}$

B.  $\left\{\frac{-1 \pm \sqrt{15}}{2}\right\}$

C.  $\left\{\frac{-1 \pm \sqrt{11}}{2}\right\}$

D.  $\left\{\frac{-1 \pm \sqrt{13}}{2}\right\}$

E.  $\left\{\frac{-1 \pm \sqrt{7}}{2}\right\}$

**Resuelve los siguientes problemas:**

26. Un determinado grupo de estudiantes gana 324 soles en una rifa, pero en el momento de la entrega no se presentan 3 ellos, lo que trae como consecuencia que a cada uno de los estudiantes restantes le corresponda 9 soles más. ¿Cuántos estudiantes recibieron el dinero? .
- A. 5                      B. 6                      C. 7                      D. 8                      E. 9
27. La suma de dos números es 21 y su producto es igual a 10 veces su diferencia. ¿Cuáles son los números? .
- A. 14 y 7                B. 10 y 11              C. 15 y 6                D. 13 y 8                E. 19 y 2
28. Determina las dimensiones de un terreno de forma rectangular, sabiendo que su largo excede a su ancho en 8 metros; y que, si al ancho se le aumenta 4 metros y al largo 10 metros, entonces su área se duplica.
- A. 12m y 20m          B. 11m y 19m          C. 10m y 19m          D. 9m y 18m          E. 8m y 17m
29. Dos llaves abiertas al mismo tiempo llenan con agua un estanque en 8 minutos. Si solo abrimos la primera llave demora 30 minutos menos que la segunda, ¿qué tiempo demorará en llenar el estanque la segunda llave?
- A. 39min                B. 40min                C. 41min                D. 42min                E. 43min
30. En una colecta misionera se reunió 140 monedas. ¿Cuántas personas colaboraron, si el número de monedas que dio cada una excede en 4 al número de personas?
- A. 9                      B. 8                      C. 10                      D. 13                      E. 11

Tabla de respuestas de la semana 2							
16.	A	17.	B	18.	C	19.	E
20.	A	21.	A	22.	C	23.	E
24.	B	25.	D	26.	E	27.	C
28.	A	29.	B	30.	C		

Tabla de firmas del padre de familia de control diario de la semana 2				
Lunes, 8 de enero	Martes, 9 de enero	Miércoles, 10 de enero	Jueves, 11 de enero	Viernes, 12 de enero

**Semana 3**

**Tema: Sistemas de ecuaciones de primer grado con dos variables.**

Utilizando el método más conveniente, halla el conjunto solución de:

31. 
$$\begin{cases} \frac{x-2}{4} + \frac{y+1}{3} = 2 \\ \frac{x+1}{7} + \frac{y-3}{2} = \frac{1}{2} \end{cases}$$

- A.  $\{(6;2)\}$             B.  $\{(6;1)\}$             C.  $\{(6;3)\}$             D.  $\{(4;2)\}$             E.  $\{(5;2)\}$

32. 
$$\begin{cases} \frac{x+y}{x-y} = -\frac{7}{2} \\ 8x+y-1 = 2x-2y-4 \end{cases}$$

- A.  $\{(-4;9)\}$             B.  $\{(-5;9)\}$             C.  $\{(-3;9)\}$             D.  $\{(-2;9)\}$             E.  $\{(-1;9)\}$

$$33. \begin{cases} \frac{x-2}{x+2} = \frac{y-7}{y-5} \\ \frac{x+1}{x-1} = \frac{y-3}{y-5} \end{cases}$$

- A.  $\{(0;8)\}$       B.  $\{(1;8)\}$       C.  $\{(2;8)\}$       D.  $\{(3;8)\}$       E.  $\{(4;8)\}$

$$34. \begin{cases} 4(x-3) - 3(y-4) = 0 \\ \frac{x-4}{2} + \frac{y+2}{5} = 3 \end{cases}$$

- A.  $\{(7;8)\}$       B.  $\{(8;8)\}$       C.  $\{(6;8)\}$       D.  $\{(9;8)\}$       E.  $\{(8;9)\}$

**Resuelve los siguientes problemas:**

35. El tercer grado A de la I. E. "Presbítero Maestro" de Wichanza, tiene 40 alumnos entre hombres y mujeres. Si el triple de la cantidad de hombres excede en 8 a la mitad de la cantidad de mujeres, ¿cuál es la cantidad de hombres que hay en dicha sección?  
 A) 8      B) 10      C) 12      D) 14      E) 16
36. Un salón de recepciones acoge a 100 personas entre hombres y mujeres. Si cada caballero pagó S/ 25 por la entrada y cada dama pagó S/ 10 por el mismo concepto, siendo la recaudación total de S/ 2050, ¿cuántos hombres más que mujeres asistieron a la reunión?  
 A) 34      B) 36      C) 38      D) 40      E) 42
37. Calcular dos números de modo que el triple del mayor exceda en 162 al número menor y que el duplo del mayor, aumentado en el quintuple del menor resulte 210.  
 A) 34 y 29      B) 36 y 40      C) 60 y 18      D) 40 y 31      E) 42 y 49
38. Al dividir una varilla de 80 cm en dos partes, resulta que un quinto de la parte mayor excede en 4 cm a un séptimo de la parte menor. ¿Cuánto mide la parte mayor?  
 A) 45 cm      B) 50 cm      C) 40 cm      D) 35 cm      E) 20 cm
39. La señora Margarita gastó S/ 760 haciendo compras en el mercado. Utilizó 40 billetes de S/ 10 y de S/ 50 . ¿Cuántos billetes de S/ 50 gastó?  
 A) 10      B) 3      C) 5      D) 7      E) 9
40. Se compró 24 Kg de productos entre azúcar y arroz. Si un Kg de azúcar cuesta S/ 3 y un Kg de arroz cuesta S/ 2, ¿cuántos kilogramos de arroz se compró, si el gasto total fue de S/ 64?  
 A) 6 kg      B) 8 kg      C) 10 kg      D) 12 kg      E) 14 kg

**Tema: Triángulos: elementos, clasificación y propiedades**

41. Calcula el ángulo x.

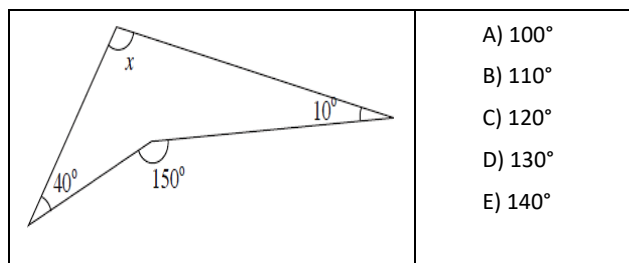

42. Calcula el valor de  $x$ , si  $\overline{AF}$  es la bisectriz del  $\angle BAC$ .

	<p>A) <math>100^\circ</math></p> <p>B) <math>115^\circ</math></p> <p>C) <math>120^\circ</math></p> <p>D) <math>125^\circ</math></p> <p>E) <math>130^\circ</math></p>
--	--

43. Según la figura, calcula el valor del ángulo  $x$ .

	<p>A) <math>40^\circ</math></p> <p>B) <math>45^\circ</math></p> <p>C) <math>50^\circ</math></p> <p>D) <math>60^\circ</math></p> <p>E) <math>55^\circ</math></p>
--	---

44. Calcula el valor de  $a + b - c$ .

	<p>A) <math>80^\circ</math></p> <p>B) <math>85^\circ</math></p> <p>C) <math>90^\circ</math></p> <p>D) <math>95^\circ</math></p> <p>E) <math>100^\circ</math></p>
--	--

45. Calcula el valor del ángulo C.

	<p>A) <math>80^\circ</math></p> <p>B) <math>82^\circ</math></p> <p>C) <math>84^\circ</math></p> <p>D) <math>86^\circ</math></p> <p>E) <math>88^\circ</math></p>
--	---

Tabla de respuestas de la semana 3

31.	A	32.	B	33.	E	34.	C
35.	A	36.	D	37.	C	38.	A
39.	E	40.	B	41.	A	42.	D
43.	B	44.	E	45.	A		

Tabla de firmas del padre de familia de control diario de la semana 3

Lunes, 15 de enero	Martes, 16 de enero	Miércoles, 17 de enero	Jueves, 18 de enero	Viernes, 19 de enero

**Semana 4**

**Tema: Triángulos: elementos, clasificación y propiedades.**

46. Calcula el ángulo PDQ.

	<p>A) <math>80^\circ</math></p> <p>B) <math>82^\circ</math></p> <p>C) <math>84^\circ</math></p> <p>D) <math>86^\circ</math></p> <p>E) <math>88^\circ</math></p>
--	---

47. Calcula el valor de  $x$ , si  $BE = EC$  y  $BC = BD$ .

	<p>A) <math>28^\circ</math></p> <p>B) <math>30^\circ</math></p> <p>C) <math>32^\circ</math></p> <p>D) <math>34^\circ</math></p> <p>E) <math>36^\circ</math></p>
--	---

48. Halla el mayor perímetro posible para el triángulo ABC, si sus lados son valores enteros.

	<p>A) 18 m</p> <p>B) 20 m</p> <p>C) 22 m</p> <p>D) 24 m</p> <p>E) 26 m</p>
--	--

49. Si  $\overline{PR} \parallel \overline{ST}$ , calcula  $x + y$ .

	<p>A) <math>110^\circ</math></p> <p>B) <math>112^\circ</math></p> <p>C) <math>114^\circ</math></p> <p>D) <math>116^\circ</math></p> <p>E) <math>120^\circ</math></p>
--	--

50. Si  $\overline{PR} \parallel \overline{ST}$ , calcula el valor de  $x$ .

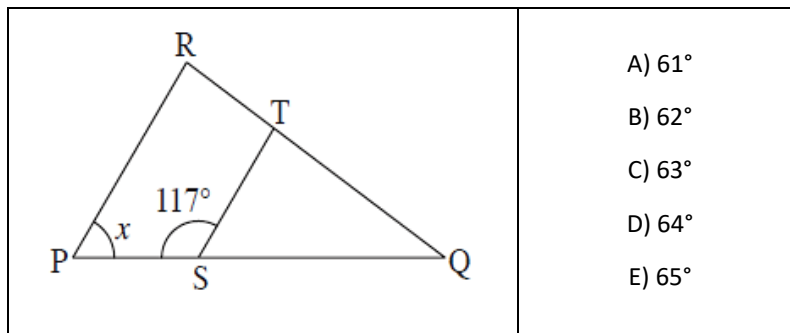

- A)  $61^\circ$
- B)  $62^\circ$
- C)  $63^\circ$
- D)  $64^\circ$
- E)  $65^\circ$

**Tema: Líneas y puntos notables en el triángulo**

51. Calcula la medida de uno de los ángulos exteriores de un triángulo equilátero.  
 A)  $120^\circ$       B)  $100^\circ$       C)  $110^\circ$       D)  $115^\circ$       E)  $105^\circ$
52. En un triángulo ABC,  $m\angle A = 20^\circ$  y  $m\angle C = 32^\circ$ , se traza la bisectriz interior  $\overline{BD}$ . Calcula la  $m\angle BDC$ .  
 A)  $80^\circ$       B)  $81^\circ$       C)  $82^\circ$       D)  $83^\circ$       E)  $84^\circ$
53. En un triángulo ABC,  $m\angle A = 70^\circ$  y  $m\angle B = 60^\circ$ , se traza la altura  $\overline{BH}$ . Calcula la  $m\angle HBC$ .  
 A)  $10^\circ$       B)  $40^\circ$       C)  $30^\circ$       D)  $25^\circ$       E)  $41^\circ$
54. En un triángulo ABC, se toma sobre AC un punto D, tal que  $BD=DC=AB$ . Si el ángulo  $BCD=18^\circ$ , ¿cuánto mide el ángulo BAD?  
 A)  $34^\circ$       B)  $35^\circ$       C)  $36^\circ$       D)  $37^\circ$       E)  $38^\circ$
55. En un triángulo MNP las bisectrices exteriores del  $\angle M$  y  $\angle P$  se cortan en O y la bisectriz interior del  $\angle M$  con la bisectriz exterior del  $\angle P$  se corta en Q. Si el ángulo O es el doble del ángulo Q, halla el ángulo N.  
 A)  $45^\circ$       B)  $37^\circ$       C)  $16^\circ$       D)  $53^\circ$       E)  $60^\circ$
56. Un ángulo exterior de un triángulo mide  $100^\circ$ . Calcula el ángulo formado por las bisectrices interiores de los otros dos ángulos.  
 A)  $130^\circ$       B)  $125^\circ$       C)  $116^\circ$       D)  $153^\circ$       E)  $150^\circ$
57. En un triángulo ABC, el ángulo que forman la bisectriz y la altura trazada desde B mide  $20^\circ$ . Calcula el valor de  $2(m\angle A) + 2(m\angle B)$ .  
 A)  $200^\circ$       B)  $190^\circ$       C)  $210^\circ$       D)  $220^\circ$       E)  $218^\circ$
58. En un triángulo ABC, la mediatriz de  $\overline{BC}$  corta a  $\overline{AC}$  en el punto E. Halla la medida de  $\overline{EC}$  si  $\overline{AB} = 12$  cm,  $m\angle A = 78^\circ$  y  $m\angle C = 39^\circ$ .  
 A) 18 cm      B) 24 cm      C) 6 cm      D) 12 cm      E) 14 cm
59. En el triángulo ABC se traza  $\overline{BE}$  ( $E \in \overline{AC}$ ) de modo que sea bisectriz del ángulo ABC. Si  $AB = BC + EC$ , calcula  $m\angle A$ .  
 A)  $30^\circ$       B)  $40^\circ$       C)  $45^\circ$       D)  $38^\circ$       E)  $50^\circ$
60. En un triángulo ABC, se traza la mediana AM, luego se traza la ceviana BF ( $F \in \overline{AC}$ ) que interseca a  $\overline{AM}$  en D tal que  $AD=DM$ . Si  $AC = 12$  cm, determina el valor de AF.  
 A) 6 cm      B) 8 cm      C) 4 cm      D) 12 cm      E) 10 cm

Tabla de respuestas de la semana 4							
46.	C	47.	A	48.	A	49.	E
50.	C	51.	A	52.	E	53.	B
54.	C	55.	E	56.	A	57.	D
58.	D	59.	B	60.	C		

Tabla de firmas del padre de familia de control diario de la semana 4				
Lunes, 22 de enero	Martes, 23 de enero	Miércoles, 24 de enero	Jueves, 25 de enero	Viernes, 26 de enero



## **Inventario de ejercicios, problemas y actividades de Comunicación (tercer grado de secundaria)** **(Apoyo a la recuperación académica 2017)**

Estimado estudiante:

Te proponemos el presente inventario de ejercicios y problemas (actividades para otras áreas) como un recurso de apoyo para el proceso de recuperación académica que debes seguir durante el mes de enero de 2018. Te pedimos tener presente, respecto al inventario, lo siguiente:

- Ha sido elaborado de acuerdo con el temario de la evaluación de salida del cuarto bimestre.
- Los ejercicios y problemas que se presenta en él han sido tomados de los documentos de trabajo del año escolar 2017 y de otras fuentes, pero que se ajustan a los contenidos del temario.
- Ha sido dosificado para ser desarrollado en cuatro semanas, de lunes a viernes, destinando para ello una hora diaria aproximadamente.
- Debe ser impresa en pliegos de papel bond. Su presentación será en un fólder manila tamaño oficio (incluir carátula), el mismo que será revisado y evaluado por los docentes responsables de la evaluación de recuperación, asignándole un peso de 25 % en el resultado final de la recuperación como "evaluación de portafolio". De hecho, si no lo presentares desarrollado, se te asignará la nota mínima en evaluación de portafolio.
- Si los estudiantes requiriesen presentarse a la segunda oportunidad, podrán mejorar y volver a presentarlo desarrollado, prevaleciendo, en este caso, la segunda calificación. Si no lo hiciesen, mantendrán la calificación obtenida en la primera ocasión.
- En la tabla de control diario, el padre de familia debe firmar para apoyar y controlar el avance diario del estudiante en su desarrollo.
- No hemos incluido una calendarización específica para su desarrollo (fechas de inicio y fin), asumiendo que cada estudiante lo hará en coordinación con sus padres, considerando la realidad particular y los planes de la familia. En todo caso, el trabajo ha sido previsto para cuatro semanas.
- La primera oportunidad de evaluación será a fines de enero. La presentación del portafolio (inventario desarrollado) es obligatoria desde la primera oportunidad de evaluación.

### **Semana 1**

<b>Tema</b>	<b>Páginas</b>	<b>Ejercicios y actividades</b>	<b>Firma</b>
Texto argumentativo	2	Anexo 1	
Géneros y especies líricas	2-3	Anexo 2	

### **Semana 2**

<b>Tema</b>	<b>Páginas</b>	<b>Ejercicios y actividades</b>	<b>Firma</b>
El renacimiento: Fray Luis de León	4	Anexo 3	
Plan de redacción	5-6	Anexo 4	

### **Semana 3**

<b>Tema</b>	<b>Páginas</b>	<b>Ejercicios y actividades</b>	<b>Firma</b>
Realismo: Benito Pérez Galdós	7	Anexo 5	
Generación del 98: Antonio Machado	8-9	Anexo 6	



<<Asomaba a sus ojos una lágrima  
y a mi labio una frase de perdón;  
habló el orgullo y se enjugó su llanto,  
y la frase en mis labios expiró.

Yo voy por un camino; ella, por otro;  
pero, al pensar en nuestro mutuo amor,  
yo digo aún: —¿Por qué callé aquel día?  
Y ella dirá: —¿Por qué no lloré yo?>>.

**Gustavo Adolfo Bécquer**

1. **Especie lírica:** \_\_\_\_\_  
¿Por qué? \_\_\_\_\_

2. **Tema:** \_\_\_\_\_

<<Al perderte yo a ti tú y yo hemos perdido:  
yo porque tú eras lo que yo más amaba  
y tú porque yo era el que te amaba más.  
Pero de nosotros dos tú pierdes más que yo:  
porque yo podré amar a otras como te amaba a ti  
pero a ti no te amarán como te amaba yo>>.

**Ernesto Cardenal**

1. **Especie lírica:** \_\_\_\_\_  
¿Por qué? \_\_\_\_\_

2. **Tema:** \_\_\_\_\_

<<La misma mesa antigua y holgada, de nogal  
y sobre ella la misma blancura del mantel  
y los cuadros de caza de anónimo pincel  
y la oscura alacena, todo, todo está igual...  
Hay un sitio vacío en la mesa hacia el cual  
mi madre tiende a veces su mirada de miel  
y se musita el nombre del ausente; pero él  
hoy no vendrá a sentarse en la mesa pascual>>.

**Abraham Valdelomar**

1. **Especie lírica:** \_\_\_\_\_  
¿Por qué? \_\_\_\_\_

2. **Tema:** \_\_\_\_\_

EL RENACIMIENTO: FRAY LUIS DE LEÓN

**Instrucción.** Lee el texto propuesto; luego, contesta las preguntas.

**Vida retirada**

<< ¡Qué descansada vida  
la del que huye del **mundanal ruido**,  
y sigue **la escondida**  
**senda**, por donde han ido  
los pocos sabios que en el mundo han sido!

Que no le enturbia el pecho  
de los soberbios grandes el estado,  
ni del dorado techo  
se admira, fabricado  
del sabio moro, en jaspe sustentado.

No cura si la fama  
canta con voz su nombre pregonera,  
ni cura si encarama  
la lengua lisonjera  
lo que condena la verdad sincera.

¿Qué presta a mi contento  
si soy del vano dedo señalado;  
sí, en busca deste viento,  
ando desalentado  
con ansias vivas, con mortal cuidado?

¡Oh monte, oh fuente, oh río!  
¡Oh secreto seguro, deleitoso!  
Roto casi el navío,  
a vuestro almo reposo  
huyo de aqueste mar tempestuoso (...)>>.

**Fray Luis de León**

1. ¿Qué sentimientos predominan en el poeta?

---

2. ¿Qué representa el mundanal ruido y la escondida senda en el texto?

---

3. ¿Qué características literarias presenta el texto leído?

---

## PLAN DE REDACCIÓN

**Instrucción:** Lee los textos y, luego anota el orden en que deben usarse los enunciados.

### 1. ¿Cómo afrontan el invierno polar los animales?

- A. Sin embargo, para muchos mamíferos y pájaros los crudos inviernos son más de los que pueden soportar; por eso, migran hacia lugares más cálidos y regresan en primavera.
- B. Cuando se acerca el invierno, algunos mamíferos desarrollan pelajes gruesos que pueden ser blancos para su camuflaje en la nieve.
- C. Además, almacenan una gruesa capa de grasa en su piel para retener calor y funcionar como reserva nutritiva.
- D. Para sobrevivir a las estaciones tan contrapuestas de los polos, los animales sufren ciertos cambios.
- E. Los pájaros también cuentan con capas de grasa y plumaje denso para aislarse del frío.

**Ordenamiento:** \_\_\_\_\_

### 2. Las anfetaminas

- A. Sin embargo, con el paso del tiempo, la gente comenzó a darse cuenta de que sus efectos nocivos superaban su utilidad.
- B. Por esta razón, fueron prohibidas; hoy en día, se ingieren bajo estricta supervisión médica o ilegalmente.
- C. Es frecuente que los efectos secundarios de un fármaco no salgan a la luz hasta que miles de personas lo hayan tomado.
- D. Los nuevos fármacos tienen que someterse a controles muy rigurosos antes de realizarse las primeras pruebas en humanos.
- E. Este es el caso de las anfetaminas, cuyo uso como píldoras de adelgazamiento fue muy popular en la década de 1950.

**Ordenamiento:** \_\_\_\_\_

### 3. El cine de animación

- A. Pero será Walt Disney quien ruende el primer largometraje de animación.
- B. Actualmente, el desarrollo de técnicas informativas y de síntesis de imagen han abierto nuevas perspectivas dentro del género.
- C. El francés Émile Reynaud, con sus praxinoscopio y después con su teatro óptico, puede ser considerado como el pionero de la animación.
- D. En Estados Unidos, las técnicas se perfeccionan y abren vías a las experimentaciones de Pat Sullivan.
- E. Sin embargo, será el estadounidense J. Stuart Blackton quien descubra las tomas fotograma a fotograma, un elemento fundamental dentro de este género.

**Ordenamiento:** \_\_\_\_\_

### 4. La pila seca

- A. Su periodo de vida suele ser de varias semanas.
- B. Las pilas secas son tal vez los elementos de mayor uso en aparatos eléctricos portátiles.
- C. Las pilas secas comerciales tienen una fuerza de 1,5 y una resistencia interna de 0, 1 ohmios, aproximadamente.
- D. A diferencia de la pila voltaica, en las pilas secas la disolución acuosa de ácido es reemplazada por una pasta de dióxido de manganeso y carbón.

**Ordenamiento:** \_\_\_\_\_

## 5. La línea en el dibujo

- A. Sin embargo, si observamos cualquier objeto, veremos que no exista ningún tipo de línea que defina su contorno.
- B. La línea es el elemento gráfico esencial del dibujo.
- C. Por ello, se afirma que la línea de contorno es un artificio ideado por el ser humano para hacer posible la representación mediante el dibujo.
- D. Con la línea se puede dibujar el contorno de las cosas y delimitar las formas concretas o abstractas.
- E. Este se delimita más bien por la diferencia de color existente entre el objeto y el fondo.

**Ordenamiento:** \_\_\_\_\_

## 6. El viaje de Mauricio

- A. La región de Magreb le llamó particularmente la atención.
- B. Tras buscar información, se interesó por algunos de los países del norte de África.
- C. Mauricio ganó un premio consistente en un tour para el país de su elección, en África.
- D. Ya en Rabat, la capital, lo esperaba un guía que lo iba a acompañar en todo el viaje.
- E. Se decidió por Marruecos, porque la cultura de los bereberes le interesa mucho.

**Ordenamiento:** \_\_\_\_\_

## 7. El surgimiento de los Estados Unidos

- A. Las colonias se rebelan contra el poder inglés a causa de la promulgación de una serie de leyes llamadas *Intolerable Acts*.
- B. Los ingleses toman el control de la zona, comprobando o conquistando los territorios holandeses.
- C. El gobierno del nuevo país inicia acciones para conquistar y colonizar los vastos territorios del oeste norteamericano.
- D. Colonos holandeses e ingleses llegan a la zona este de Norteamérica.
- E. Tras una larga guerra, los colonos logran su independencia en 1776.

**Ordenamiento:** \_\_\_\_\_

## 8. Zeus

- A. Zeus agradeció a Amaltea sus cuidados poniéndola en el cielo como una constelación: Capricornio.
- B. La sola vista de la opulenta nodriza infundía temor incluso a los inmortales.
- C. Fue hijo de Cronos y de Rea.
- D. Rea lo ocultó en el monte Licea, donde la cabra Amaltea lo alimentó con su excelente leche.
- E. Cuando nació, su madre evitó que Cronos lo devorara reemplazándola por una piedra envuelta en pañales.

**Ordenamiento:** \_\_\_\_\_

**REALISMO: BENITO PÉREZ GALDÓS**

**Instrucción.** Lee el texto propuesto y aplica las técnicas para la comprensión lectora. Luego desarrolla las indicaciones.

**Marianela**

<< (...) - ¡Pobre criatura! -dijo Carlos-. ¡Quién ha de decir que eso tiene diez y seis años!

-Atrasadilla está. ¡Qué desgracia! -exclamó Sofía-. Y yo me pregunto, ¿para qué permite Dios que tales criaturas vivan?... Y me pregunto también, ¿qué es lo que se puede hacer por ella? Nada, nada más que darle de comer, vestirla hasta cierto punto... Ya se ve... rompe todo lo que le ponen encima. Ella no puede trabajar, porque se desmaya; ella no tiene fuerzas para nada. Saltando de piedra en piedra, subiéndose a los árboles y jugando y enredando todo el día y cantando como los pájaros, cuanto se le pone encima conviértase pronto en jirones...

-Pues yo he observado en la Nela -dijo Carlos- algo de inteligencia y agudeza de ingenio bajo aquella corteza de candor y salvaje rusticidad. No, señor, la Nela no es tonta ni mucho menos. Si alguien se hubiera tomado el trabajo de enseñarle alguna cosa, habría aprendido mejor quizás que la mayoría de los chicos. ¿Qué creen ustedes? La Nela tiene imaginación; por tenerla y carecer hasta de la enseñanza más rudimentaria, es sentimental y supersticiosa.

-Eso es, se halla en la situación de los pueblos primitivos -dijo Teodoro-. Está en la época del pastoreo.

-Ayer precisamente -añadió Carlos- pasaba yo por la Trascava y la vi en el mismo sitio donde la hemos hallado hoy. La llamé, hícela salir, le pregunté qué hacía en aquel sitio, y con la mayor sencillez del mundo me contestó que estaba hablando con su madre... Tú- no sabes que la madre de la Nela se arrojó por esa sima.

-Es decir, que se suicidó -dijo Sofía-. Era una mujer de mala vida y peores ideas, según he oído contar. Carlos no estaba aquí todavía; pero nos han dicho que se embriagaba como un fogonero. Y yo me pregunto: ¿Esos seres tan envilecidos que terminan una vida de crímenes con el mayor de todos, que es el suicidio, merecen la compasión del género humano? Hay cosas que horripilan; hay personas que no debieran haber nacido, no señor, y Teodoro podrá decir todas las sutilezas que quiera, pero yo me pregunto...

-No, no te preguntes nada, hermana querida -dijo vivamente Teodoro-. Yo te responderé que el suicida merece la más viva, la más cordial compasión. En cuanto a vituperio, échesele encima todo el que haya disponible, pero al mismo tiempo... bueno será indagar qué causas le llevaron a tan horrible extremo de desesperación... yo observaría si la sociedad no le ha dejado abierta, desamparándole en absoluto, la puerta de ese abismo horrendo que le llama (...)>>

1. ¿Cómo caracterizan a Marianela?

---

2. ¿Qué definición del suicidio tiene Teodoro?

---

3. Redacta los hechos principales.

---

---

GENERACIÓN DEL 98: ANTONIO MACHADO

**Instrucción:** Lee y analiza el poema Ensueños.

*Yo voy soñando caminos  
de la tarde. ¡Las colinas  
doradas, los verdes pinos,  
las polvorientas encinas!*

*¿A dónde el camino irá?  
yo voy cantando, viajero  
a lo largo del sendero...  
-La tarde cayendo está-*

*En el corazón tenía  
la espina de una pasión;  
logré arrancármela un día:  
ya no siento el corazón.*

*Y todo el campo un momento  
se queda, mudo y sombrío,  
meditando. Suena el viento  
en los álamos del río.*

*La tarde más se oscurece;  
y el camino se serpea  
y débilmente blanquea,  
se enturbia y desaparece.*

*Mi cantar vuelve a plañir:  
Aguda espina dorada,  
quién te volviera a sentir  
en el corazón clavada.*

**Antonio Machado**

**Analiza el poema de acuerdo al esquema establecido.**

1. Género: \_\_\_\_\_
2. Formas de composición: \_\_\_\_\_
3. Versos: \_\_\_\_\_
4. Rima: \_\_\_\_\_
5. Figuras literarias: \_\_\_\_\_
6. Ideas principales (por estrofa):
  - Idea 1: \_\_\_\_\_
  - Idea 2: \_\_\_\_\_
  - Idea 3: \_\_\_\_\_
  - Idea 4: \_\_\_\_\_
  - Idea 5: \_\_\_\_\_
  - Idea 6: \_\_\_\_\_
7. Tema: \_\_\_\_\_
8. Símbolos: \_\_\_\_\_



9. Características literarias: \_\_\_\_\_

## Anexo 7

### GENERACIÓN DEL 27: FEDERICO GARCÍA LORCA

**Instrucción.** Lee el texto propuesto y aplica las técnicas para la comprensión lectora. Luego desarrolla las indicaciones.

#### La casa de Bernarda Alba

<< (...) **Mujer 3:** No te faltará la hogaza de pan caliente.

**Mujer 2:** Ni el techo para tus hijas.

(Van desfilando todas por delante de Bernarda y saliendo. Sale Angustias por otra puerta, la que da al patio)

**Mujer 4:** El mismo trigo de tu casamiento lo sigas disfrutando.

**La Poncia:** (Entrando con una bolsa) De parte de los hombres esta bolsa de dineros para responsos.

**Bernarda:** Dales las gracias y échales una copa de aguardiente.

**Muchacha:** (A Magdalena) Magdalena...

**Bernarda:** (A Magdalena, que inicia el llanto) Chist. (Golpea con el bastón.) (Salen todas.) (A las que se han ido) ¡Andar a vuestras cuevas a criticar todo lo que habéis visto! Ojalá tardéis muchos años en pasar el arco de mi puerta.

**La Poncia:** No tendrás queja ninguna. Ha venido todo el pueblo.

**Bernarda:** Sí, para llenar mi casa con el sudor de sus refajos y el veneno de sus lenguas.

**Amelia:** ¡Madre, no hable usted así!

**Bernarda:** Es así como se tiene que hablar en este maldito pueblo sin río, pueblo de pozos, donde siempre se bebe el agua con el miedo de que esté envenenada.

**La Poncia:** ¡Cómo han puesto la solería!

**Bernarda:** Igual que si hubiera pasado por ella una manada de cabras. (La Poncia limpia el suelo) Niña, dame un abanico.

**Amelia:** Tome usted. (Le da un abanico redondo con flores rojas y verdes.)

**Bernarda:** (Arrojando el abanico al suelo) ¿Es este el abanico que se da a una viuda? Dame uno negro y aprende a respetar el luto de tu padre.

**Martirio:** Tome usted el mío.

**Bernarda:** ¿Y tú?

**Martirio:** Yo no tengo calor.

**Bernarda:** Pues busca otro, que te hará falta. En ocho años que dure el luto no ha de entrar en esta casa el viento de la calle. Haceros cuenta que hemos tapiado con ladrillos puertas y ventanas. Así pasó en casa de mi padre y en casa de mi abuelo. Mientras, podéis empezar a bordaros el ajuar. En el arca tengo veinte piezas de hilo con el que podréis cortar sábanas y embozos. Magdalena puede bordarlas.

**Magdalena:** Lo mismo me da.

**Adela:** (Agría) Si no queréis bordarlas irán sin bordados. Así las tuyas lucirán más.

**Magdalena:** Ni las mías ni las vuestras. Sé que yo no me voy a casar. Prefiero llevar sacos al molino. Todo menos estar sentada días y días dentro de esta sala oscura.

**Bernarda:** Eso tiene ser mujer.

**Magdalena:** Malditas sean las mujeres.

**Bernarda:** Aquí se hace lo que yo mando. Ya no puedes ir con el cuento a tu padre. Hilo y aguja para las hembras. látigo y mula para el varón. Eso tiene la gente que nace con posibles (...)>>.

### Actividades

1. ¿Qué personaje simboliza el principio de autoridad? Fundamenta tu respuesta.

---

---

2. ¿Qué relación se muestra entre padres e hijos que ya no es tan usual en la realidad?

---

---

3. Redacta los hechos principales e infiere las ideas principales.

Hechos principales	Ideas principales



## Inventario de actividades de Inglés (nivel: STARTER) (Apoyo a la recuperación académica 2017)

Estimado estudiante:

Te proponemos el presente inventario de actividades como un recurso de apoyo para el proceso de recuperación académica que debes seguir durante el mes de enero de 2018. Te pedimos tener presente, respecto al inventario, lo siguiente:

- Ha sido elaborado de acuerdo con un temario anual, el cual considera los cuatro bimestres (25 % c/u).
- Las actividades que se presenta en él han sido tomadas de documentos de trabajo, libros del año escolar 2017 y de otras fuentes, pero que se ajustan a los contenidos del temario anual.
- Ha sido dosificado para ser desarrollado en cuatro semanas, de lunes a viernes, destinando para ello una hora diaria aproximadamente.
- El estudiante debe imprimir los documentos que serán desarrollados, archivados y presentados en un fólter manila tamaño oficio (incluir carátula), el mismo que será revisado y evaluado por los docentes responsables de la evaluación de recuperación, asignándole un peso de 25 % en el resultado final de la recuperación como “evaluación de portafolio”. De hecho, si no lo presentases desarrollado, se te asignará la nota mínima en evaluación de portafolio.
- Si los estudiantes requiriesen presentarse a la segunda oportunidad, podrán mejorar y volver a presentarlo desarrollado, prevaleciendo, en este caso, la segunda calificación. Si no lo hiciesen, mantendrán la calificación obtenida en la primera ocasión.
- En la tabla de control diario, el padre de familia debe firmar para apoyar y controlar el avance diario del estudiante en su desarrollo.
- No hemos incluido una calendarización específica para su desarrollo (fechas de inicio y fin), asumiendo que cada estudiante lo hará en coordinación con sus padres, considerando la realidad particular y los planes de la familia. En todo caso, el trabajo ha sido previsto para cuatro semanas.
- La primera oportunidad de evaluación será a fines de enero. La presentación del portafolio (inventario desarrollado) es obligatoria desde la primera oportunidad de evaluación.

### Semana 1

#### Bimestre 1

Unit 2

Grammar: to be (negative, singular and plural); to be (questions and short answers); object pronouns

Vocabulary: adjectives to describe feelings; positive and negative adjectives.

### Semana 2

#### Bimestre 2

Unit 5

Grammar: present simple: affirmative, negative and interrogative forms; adverbs of frequency;

Vocabulary: free-time activities, gadgets

### Semana 3

#### Bimestre 3

Unit 8

Grammar: Present continuous: affirmative, negative and interrogative forms; like / don't like + -ING.

Vocabulary: clothes.

**Semana 4****Bimestre 4****Unit 10**

**Grammar:** Past simple: BE (was / wasn't, were/ weren't; Was he .....? / Were you ...?)

Past simple: Regular and irregular verbs: affirmative and negative forms.

**Vocabulary:** time expressions: past; the weather.

	Tabla de firmas del padre de familia de control diario				
	Lunes 1 de enero	Martes 2 de enero	Miércoles 3 de enero	Jueves 4 de enero	Viernes 5 de enero
Semana 1					
	Lunes 8 de enero	Martes 9 de enero	Miércoles 10 de enero	Jueves 11 de enero	Viernes 12 de enero
Semana 2					
	Lunes 15 de enero	Martes 16 de enero	Miércoles 17 de enero	Jueves 18 de enero	Viernes 19 de enero
Semana 3					
	Lunes 22 de enero	Martes 23 de enero	Miércoles 24 de enero	Jueves 25 de enero	Viernes 26 de enero
Semana 4					

**ANEXOS**

**Anexo 1\_bim 1**

**Anexo 2\_bim 2**

**Anexo 3\_bim 3**

**Anexo 4\_bim 4**

Bimestre 1

WEEK 1

Unit 2

Grammar: to be (negative, singular and plural); to be (questions and short answers); object pronouns

Vocabulary: adjectives to describe feelings; positive and negative adjectives.

Monday

1 Complete the words.



0 a ngry



1 s \_\_\_\_\_



2 t \_\_\_\_\_



3 h \_\_\_\_\_



4 h \_\_\_\_\_



5 w \_\_\_\_\_

2 Complete the sentences with the words in the list.

sad | bored | excited | tired | cold | hungry

0 Anna isn't happy. She's sad.

3 The weather is terrible today. I'm really \_\_\_\_\_.

1 I want some food. I'm really \_\_\_\_\_.

4 I'm \_\_\_\_\_. I want to sleep.

2 It's my birthday tomorrow. I'm so \_\_\_\_\_!

5 I'm \_\_\_\_\_. There's nothing to do.

3 Complete the sentences with the correct negative form of to be. Use contractions.

0 Sandra is from New York. She isn't from Chicago.

1 I \_\_\_\_\_ hungry.

2 We \_\_\_\_\_ thirsty, thank you.

3 You \_\_\_\_\_ late. It's only one o'clock.

4 Rio de Janeiro is in Brazil. It \_\_\_\_\_ in Mexico.

5 I don't like James and Suzanne. They \_\_\_\_\_ very friendly.

**I. Write the words in the correct order.**

sister / Bart's / Lisa. / is

Lisa is Bart's sister.

---

1 playing / saxophone. / hobby / Lisa's / is / the

---

2 one / old? / Is / Maggie / year

---

3 perfect / not / a / father. / Homer / is

---

4 the Principal's / Bart / is / office. / in

---

**II. Write complete answers.**

0. Where are you from?

I'm from Mexico.

---

1. What are you good at?

---

2. What are you interested in?

---

3. What can you do?

---

4. When is your birthday?

---

**III. Circle the correct answer.**

0. I'm to Japan / of Japan / from Japan.

1. I'm good at swimming / swimming / to swim.

2. I'm interested soccer / at soccer / in soccer.

3. I can to dance / dancing / dance.

4. Look at the / to the / the blackboard.

I. Read the text. Write true (T) or false (F).

Snowboarding's a multi-million-dollar industry. It's a new sport, but it's very popular in the USA and a big attraction in Europe. In the USA, you can snowboard at special snow parks in ski areas. People who are good at skiing, surfing and skateboarding are often good at snowboarding, too. Good balance, coordination and energy are necessary for all these sports. Imagination and creativity are important qualities for snowboarders, too.

Snowboarding's an official Olympic sport for men and for women. Individual talent is important, but a good snowboard's very important, too. It can be an expensive sport: the price of everything, including the snowboard, can be hundreds of dollars! It can also be dangerous.

- 0. Snowboarding's popular in Europe. \_\_\_\_
- 1 There are usually parks for snowboarding in ski areas in the USA. \_\_\_\_
- 2 Good snowboarders have good balance and imagination. \_\_\_\_
- 3 Only men can win Olympic medals in snowboarding. \_\_\_\_
- 4 Snowboarding isn't a cheap sport. \_\_\_\_
- 5 It's a very safe sport. \_\_\_\_

II. Write the correct pronouns in the spaces.

she - him - it - them - I - him

- a) \_\_\_\_\_ likes John. John likes her.
- b) \_\_\_\_\_ go to secondary school.
- c) I watch cartoons on TV. I love \_\_\_\_\_.
- d) Paris is a big city and \_\_\_\_\_ is beautiful!
- e) He's a good player. I play with \_\_\_\_\_.

III. Read the text and replace the underlined words with he, we, they or she.

- a) J.K.Rowling is a woman. \_\_\_\_\_ writes the Harry Potter books.
- b) Harry Potter is a special boy. \_\_\_\_\_ is a magician.
- c) Harry's friends are fantastic. \_\_\_\_\_ play Quidditch.
- d) My brother and I like all the books. \_\_\_\_\_ love the adventures!

IV. Write the correct object pronoun in the spaces.

me her them us it them her

- a) I work with Emma, and she works with \_\_\_\_.
- b) My parents know my boyfriend, and he knows \_\_\_\_\_.
- c) Sheila talks to Albert, and he listens to \_\_\_\_\_.
- d) My mom loves me, and I love \_\_\_\_\_.
- e) Ralph and Susan listen to Mrs. Brown, and she talks to \_\_\_\_\_.
- f) The cat plays with Jamie, and he plays with \_\_\_\_\_.
- g) We see the man, and he sees \_\_\_\_\_

Thursday:

# Feelings

Cut the pics and paste in a colour paper. Label them.

1 happy	2 shy	3 crazy	4 in love
5 hate	6 bored	7 sick	8 angry
9 scared	10 sad	11 tired	12 smart

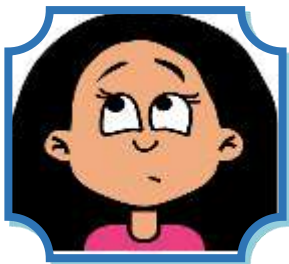
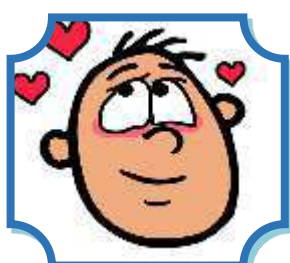
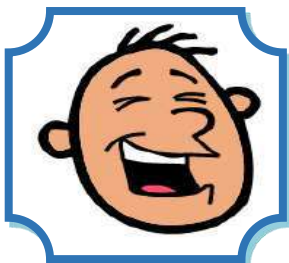



Colour the faces:

HAPPY = YELLOW

SAD = PURPLE

SICK = GREEN

ANGRY = RED

CRYING = BLUE

SURPRISED = ORANGE



Friday. Put a picture of your family and write the correct name according to the numbers.

F  
A  
M  
I  
L  
Y

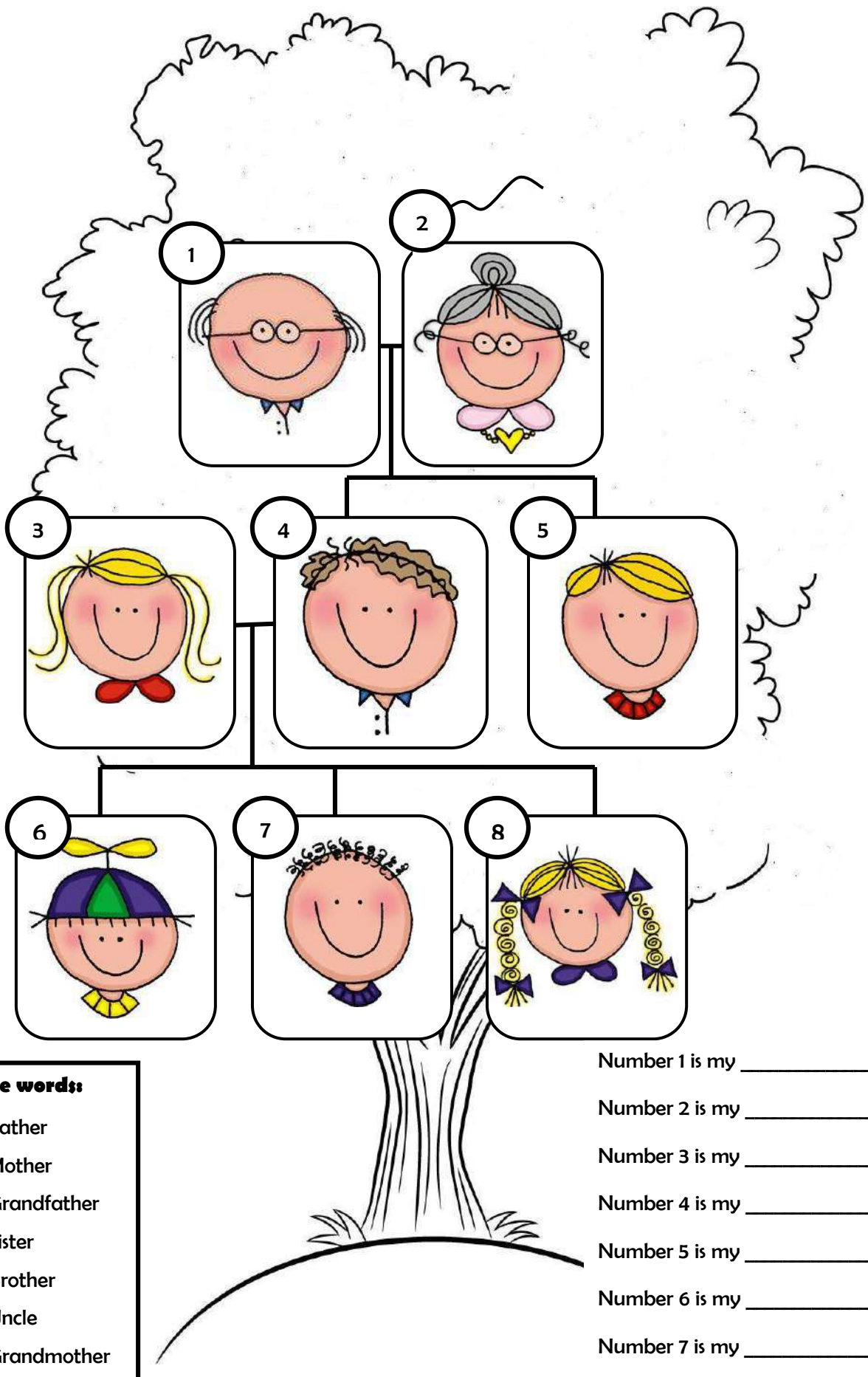

- Use these words:**
- Father
  - Mother
  - Grandfather
  - Sister
  - Brother
  - Uncle
  - Grandmother

Number 1 is my \_\_\_\_\_.

Number 2 is my \_\_\_\_\_.

Number 3 is my \_\_\_\_\_.

Number 4 is my \_\_\_\_\_.

Number 5 is my \_\_\_\_\_.

Number 6 is my \_\_\_\_\_.

Number 7 is my \_\_\_\_\_.

Number 8 is my \_\_\_\_\_.

**Monday**

Cut the pictures and play the Domino. Then paste them on a piece of color paper.



He goes to bed at ten thirty.



Marcos has lunch at twelve.



They start classes in the morning.



He does his homework.



I brush my teeth in the morning.



You go to school in the afternoon.



They take a bath at five



He studies in the morning.



She goes home at three o'clock.



You have dinner in the evening.



I have  
breakfast  
at seven  
thirty.



You take the  
bus at  
eight  
o'clock.



They visit the  
friends in  
the  
afternoon.



She buys  
food in the  
morning.



Clara listens  
to music in  
the  
evening.



I comb my  
hair in the  
morning.



They get  
dressed at  
nine  
o'clock.



She watches  
TV in the  
morning.



My father  
cooks at  
one  
o'clock.



I drink milk in  
the  
morning.



George  
sleeps at  
ten  
o'clock.



They finish  
classes at  
one  
o'clock.



Tuesday

# PRESENT SIMPLE TENSE

I. Write the correct 3rd singular person form. Remember the spelling rules!





Example: eat eats do \_\_\_\_\_  
study \_\_\_\_\_ watch \_\_\_\_\_  
drink \_\_\_\_\_ read \_\_\_\_\_  
make \_\_\_\_\_ learn \_\_\_\_\_  
tidy \_\_\_\_\_ play \_\_\_\_\_



Spelling  
rules

II. Complete the sentences. Use Present Simple affirmative.

0. My brother plays (play) football.
1. We \_\_\_\_\_ (eat) hamburgers.
2. I \_\_\_\_\_ (study) French.
3. My friends \_\_\_\_\_ (listen) to jazz music.
4. My mum \_\_\_\_\_ (like) classical music.

	He hears.
	He hides.
	They hug.
	He kicks.

III. Make the sentences negative.

0. I eat pizza.  
I don't eat pizza.
1. My brother studies German.  
\_\_\_\_\_
2. We play computer games.  
\_\_\_\_\_
3. Harry likes sport.  
\_\_\_\_\_
4. They drink water.  
\_\_\_\_\_



**She doesn't love him.**

**WEDNESDAY**

**I. Choose the correct verb form. Circle it.**

1. We **go/**goes to school by bus.
2. My teacher **speak/**speaks Italian and Japanese.
3. We **don't/**doesn't do PE in the classroom.
4. My friends don't **like/**likes art.
5. My mother **teach/**teaches in a primary school.
6. I don't **copy/**copies their homework.
7. They **finish/**finishes work at 8.30 in the evening.
8. We **don't/**doesn't think that English is easy.

**II. Write the questions in simple present in the correct order.**

0. a book / she / read / Does / ?

**Does she read a book?**

1. your teacher/Does/English/speak?

\_\_\_\_\_

2. Does/use/a computer/your mother?

\_\_\_\_\_

3. ask/your teacher/a lot of questions/Does?

\_\_\_\_\_

4. CDs and DVDs/copy/Do/you?

\_\_\_\_\_

5. on Saturday/ to school/go/you/Do?

\_\_\_\_\_

6. Do/you/French/understand?

\_\_\_\_\_

7. Does/your school/at half past three/ finish?

---

**THURSDAY**

I. Create a small graphic about the activities you do. Write 15 sentences in Present simple using adverbs of frequency in a colour paper. Then paste a picture. Example.

I **sometimes** get up at 6 o'clock.



**My routine**

I **always** take a shower at 8 o'clock.



II. Write the words for gadgets. Then put a picture.

1. Blteat \_\_\_\_\_
2. megas loscone \_\_\_\_\_
3. P3M replay \_\_\_\_\_
4. Marsthopen \_\_\_\_\_
5. Ahehndspoe \_\_\_\_\_
6. SGP \_\_\_\_\_
7. Plapto \_\_\_\_\_
8. ard-eere \_\_\_\_\_

## Friday

- I. Create a small graphic about the activities Your father does. Write 15 sentences in Present simple using adverbs of frequency in a colour paper. Then paste a picture. Example.

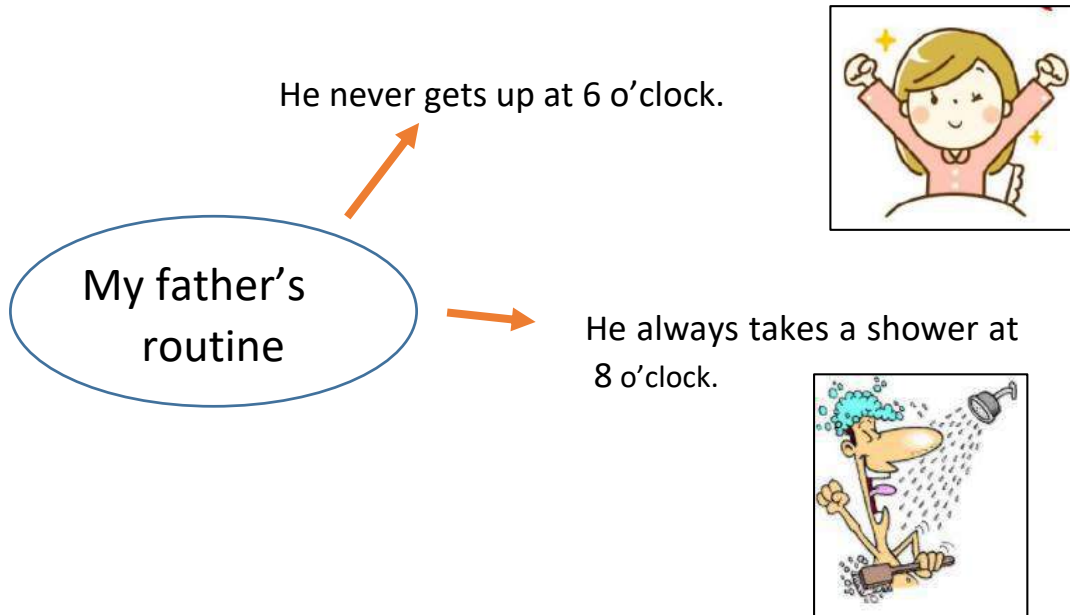



## Week 3

### Bimestre 3 - Unit 8

**Vocabulary:** clothes.

**Grammar:** Present continuous: affirmative, negative and interrogative forms; like / don't like + -ING.

#### MONDAY

COLOR THE PICTURES.

CUT THEM OUT AND MATCH THEM.

PASTE THEM IN A COLOR PAPER.

FILE IT IN A FOLDER.

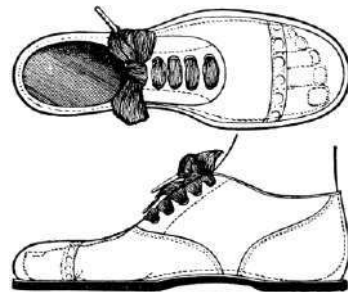

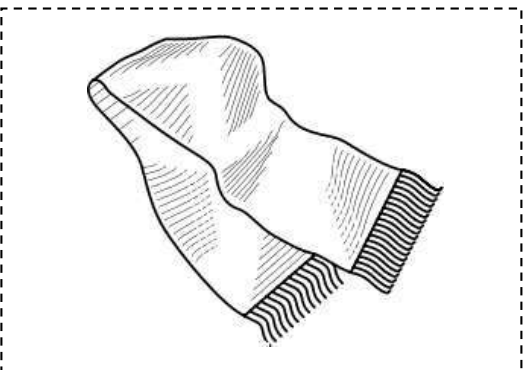
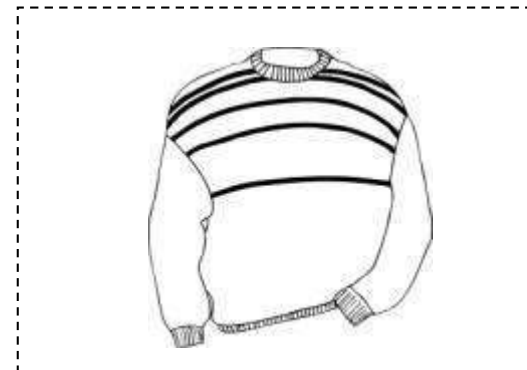

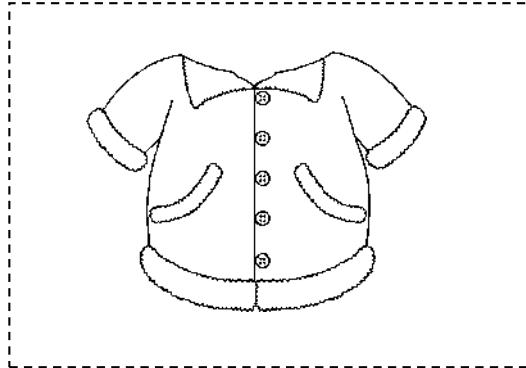
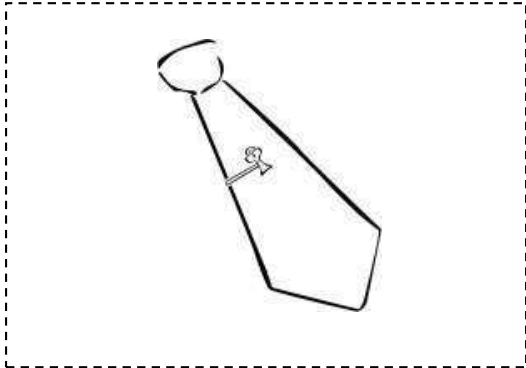
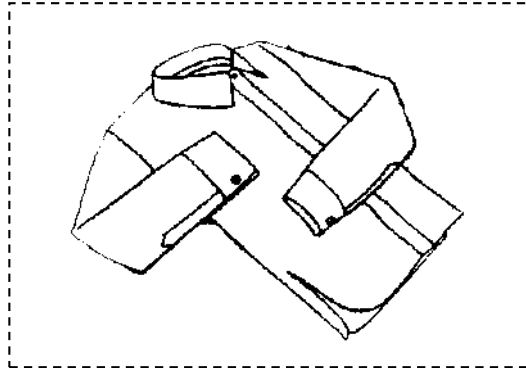
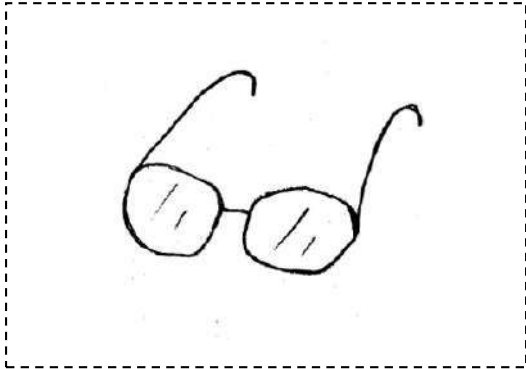

**hat**

**shoes**

**socks**

**trainers**

**dress**

**skirt**

**t-shirt**

**jacket**

**shorts**

**gloves**

**jumper**

**scarf**

**glasses**

**sunglasses**

**trousers**

**shirt**

**tie**

**coat**

**TUESDAY**

1 Complete the puzzle with names of clothes.



2 Look at the pictures and complete the sentences.



Anna is wearing a green <sup>0</sup>d\_ress and a black <sup>1</sup>c\_\_\_\_\_.

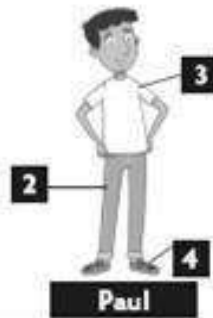

Paul is wearing blue <sup>2</sup>t\_\_\_\_\_, a white <sup>3</sup>T-\_\_\_\_\_ and <sup>4</sup>t\_\_\_\_\_.

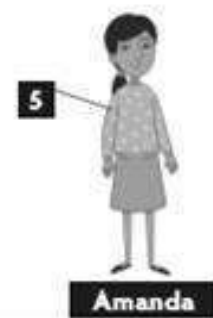

Amanda is wearing a pink <sup>5</sup>j\_\_\_\_\_.

3 Complete the sentences so that they are true for you.

- I love wearing \_\_\_\_\_.
- I hate wearing \_\_\_\_\_.
- In the winter, I usually wear \_\_\_\_\_.
- In the summer, I usually wear \_\_\_\_\_.
- At the moment, I'm wearing \_\_\_\_\_.

4 Write sentences using the present continuous.

- |              |                      |
|--------------|----------------------|
| 0 she / work | <u>She's working</u> |
| 1 I / dance  | _____                |
| 2 you / talk | _____                |
| 3 he / read  | _____                |
| 4 we / study | _____                |
| 5 they / run | _____                |

5 Write sentences with like, don't like, love or hate.

- |                                 |                        |
|---------------------------------|------------------------|
| 0 I / dance ☹️☹️                | <u>I hate dancing.</u> |
| 1 We / shop 😊😊                  | _____                  |
| 2 Simon / watch TV 😊            | _____                  |
| 3 My dog / run 😊😊               | _____                  |
| 4 I / study / at the weekend ☹️ | _____                  |
| 5 Gina / wear / skirts ☹️☹️     | _____                  |

WEDNESDAY

1 Write the *-ing* form of these verbs.

0 swim swimming

2 sit \_\_\_\_\_

4 smile \_\_\_\_\_

1 listen \_\_\_\_\_

3 dance \_\_\_\_\_

5 fly \_\_\_\_\_

2 Complete the sentences. Use the present continuous of the verbs.

0 I'm not wearing (not / wear) jeans today.

3 Jon \_\_\_\_\_ (bake) a cake.

1 My dog \_\_\_\_\_ (sit) on the chair!

4 We \_\_\_\_\_ (leave) now. Bye!

2 Bill \_\_\_\_\_ (not / talk) to Suzy.

5 My parents \_\_\_\_\_ (not / watch) TV at the moment.

3 Write the questions. Use the present continuous.

0 you / wear / coat today?

Are you wearing a coat today?

1 you / study / at the moment?

\_\_\_\_\_

2 Paul / chat / online?

\_\_\_\_\_

3 your computer / work?

\_\_\_\_\_

4 those people / play / volleyball?

\_\_\_\_\_

5 Michelle / run / in the park?

\_\_\_\_\_

4 Write short answers for the questions in Exercise 3. Use contractions where possible.

0 No, I'm not.

3 Yes, \_\_\_\_\_.

1 Yes, \_\_\_\_\_.

4 No, \_\_\_\_\_.

2 No, \_\_\_\_\_.

5 Yes, \_\_\_\_\_.

5 Circle the correct answers.

0 I hate / love swimming. I do it every morning.

4 I like / don't like talking to Mary. She's so interesting.

1 I love dance / dancing. It's my favourite hobby.

5 A Do you like run / running?

2 I don't like go / going to parties.

B Yes, but I'm not good at it.

3 I hate / like wearing skirts. I never wear them.

6 Correct the sentences. Use the words in the list.

umbrella | one person | T-shirts | football | park | next to

0 The woman is holding a bag.

The woman is holding an umbrella.

1 The boys are playing volleyball.

\_\_\_\_\_

2 They are playing on a beach.

\_\_\_\_\_

3 The women are standing behind the men.

\_\_\_\_\_

4 The boys are wearing coats.

\_\_\_\_\_

5 Two people are taking photos.

\_\_\_\_\_



**THURSDAY**

Write down- What are they doing? Use Present Continuous tense.

It is very nice weather today. The  \_\_\_\_\_ (shine),

and the birds  \_\_\_\_\_ (sing).

My family is in the garden. My mother  \_\_\_\_\_

\_\_\_\_\_ (sleep ) under the tree. My father  \_\_\_\_\_

(make) some grill chicken for dinner. My brother  \_\_\_\_\_

(play badminton) with his friend. I  \_\_\_\_\_ (wash) the car.

It is dinner time. We  \_\_\_\_\_ (sit) around the table.

FRIDAY

## Clothing line

Follow the instructions below.

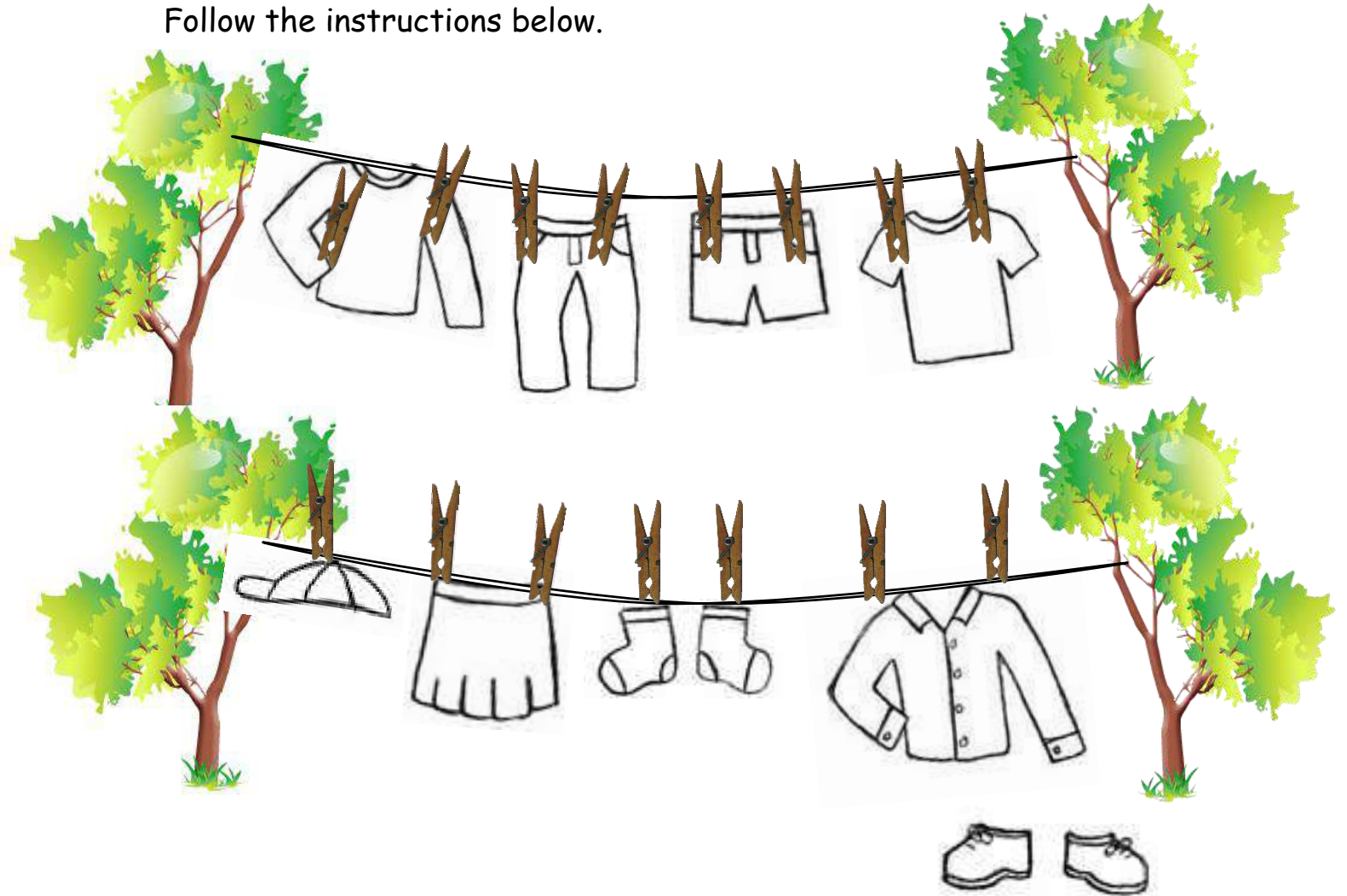

Colour the t-shirt blue.	Colour the socks green.
Colour the skirt pink.	Colour the trousers yellow.
Colour the jumper red.	Colour the shirt purple.
Colour the shoes orange.	Colour the hat black.
Colour the shorts white.	



## Week 4

### Bimestre 4 - Unit 10

**Grammar:** Past simple: BE (was / wasn't, were/ weren't; Was he .....? / Were you ...?)

Past simple: Regular and irregular verbs: affirmative and negative forms.







**Vocabulary:** time expressions: past; the weather.

<b>MONDAY</b>
---------------

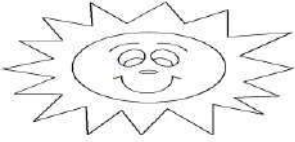
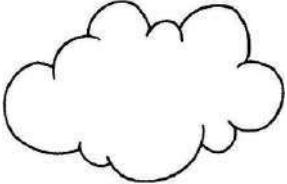
*WEATHER*

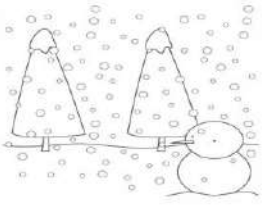
1. **Solve** the word search. **Color** the pictures and **label** them. Then **cut** them to paste them in a color paper. **File** it in a folder.

S	U	N	N	Y	A	V	Y	F
G	C	R	S	T	O	R	M	Y
T	R	S	I	M	C	O	L	D
Z	A	R	S	N	W	K	L	E
W	I	S	N	D	I	G	H	T
R	N	A	O	C	N	L	U	W
A	Y	Q	W	C	D	M	K	L
T	Z	X	Y	V	Y	S	U	W
C	L	O	U	D	Y	H	O	T

S _____	C _____	R _____	S _____
			
W _____	ST _____	H _____	C _____
			

2 Write the weather words.



0 It's sunny.

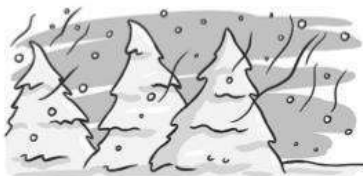

1 It's \_\_\_\_\_.



2 It's \_\_\_\_\_.



3 It's \_\_\_\_\_.



4 It's \_\_\_\_\_.

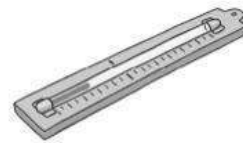

5 It's not warm, it's \_\_\_\_\_.

PAST TIME EXPRESSIONS

3 Complete the sentences with *in, at, last, or yesterday*.

0 Yesterday afternoon, I was with Jenny in the café.

1 I finished my homework \_\_\_\_\_ midnight.

2 I was at the party \_\_\_\_\_ weekend.

3 My grandmother was born \_\_\_\_\_ 1946.

4 I arrived in London \_\_\_\_\_ morning.

5 It snowed a lot \_\_\_\_\_ month.

**TUESDAY (revise the last page of your workbook - irregular verbs)**

**LOOK AT THE PICTURES AND FILL IN THE CROSSWORD PUZZLE.**

13  build

14  speak

12  read

11  eat

10  forgive

9  write

1  bite

2  ride

3  burn

4  learn

5  give

6  cut

7  leave

8  come

1 2 3 4 5 6 7 8 9

10. 11. 12. 13. 14.

**THE HIDDEN WORDS ARE \_\_\_\_\_.**

## WEDNESDAY

### 1 Circle the correct words.

- 0 It was / were sunny yesterday.
- 1 I was / were born in 1997.
- 2 I'm sorry we was / were late today.
- 3 My grandfather was / were a police officer.
- 4 You was / were a very beautiful baby.
- 5 John and Kinga was / were very happy when they lived in Madrid.

### 2 Complete the sentences with *was*, *wasn't*, *were*, or *weren't*.

- 0 It wasn't very warm yesterday. It was cold.
- 1 You \_\_\_\_\_ so sad yesterday. What was the problem?
- 2 I arrived home late last night, but my parents \_\_\_\_\_ angry.
- 3 Michael \_\_\_\_\_ very worried before his exam, but he did OK in the end.
- 4 My mother \_\_\_\_\_ born in July, her birthday is in June.
- 5 We \_\_\_\_\_ late because we missed our train.

### 3 Put the words in order to make questions.

- 0 at / were / park / yesterday / you / the
- 1 morning / I / was / this / late
- 2 keys / were / in / your coat / the
- 3 Anna / party / last / at / was / the / night
- 4 interesting / were / books / those
- 5 the / busy / was / restaurant

*Were you at the park yesterday?* \_\_\_\_\_

\_\_\_\_\_

\_\_\_\_\_

\_\_\_\_\_

\_\_\_\_\_

### 4 Write short answers for the questions in Exercise 6.

- 0 No, I wasn't.
- 1 Yes, \_\_\_\_\_.
- 2 No, \_\_\_\_\_.
- 3 Yes, \_\_\_\_\_.
- 4 Yes, \_\_\_\_\_.
- 5 No, \_\_\_\_\_.

### 5 Complete the sentences with the past simple form of the verbs in brackets.

- 0 I helped (help) Matteo a lot when he was ill.
- 1 I \_\_\_\_\_ (hate) vegetables when I was a child.
- 2 We \_\_\_\_\_ (move) to Paris in 2014.
- 3 I \_\_\_\_\_ (start) a new book last night.
- 4 Liam \_\_\_\_\_ (try) to call George, but he was busy.
- 5 Nora and Rob \_\_\_\_\_ (work) a lot last week.



# JUSTIN BIEBER

## I.- Complete the story with verbs in the past.

Justin Bieber \_\_\_\_\_(be) born in 1994, in Stratford, Ontario, Canada. As a child, He \_\_\_\_\_(have) a lot of interest on music. He \_\_\_\_\_(begin) to perform when he \_\_\_\_\_(be) 12. He \_\_\_\_\_(enter) to a local talent competition, and he \_\_\_\_\_(be) placed second. He \_\_\_\_\_(get) the opportunity of posting his performances in YouTube.

The videos soon \_\_\_\_\_(build) up a fan following, and \_\_\_\_\_(catch) the attention of talent agent Scooter Braun. Braun \_\_\_\_\_(be) able to secure an audition with Usher Raymond, who \_\_\_\_\_(be) impressed and \_\_\_\_\_(help) Bieber to sign a record deal. His first single "One Time", \_\_\_\_\_(be) a worldwide hit. This was \_\_\_\_\_(follow) by Bieber's debut album, "My World", which \_\_\_\_\_(be) an international smash. He also \_\_\_\_\_(release) a successful concert film Justin Bieber: Never Say Never in 2011.

Bieber \_\_\_\_\_(try) his hand at acting. He \_\_\_\_\_(play) a young killer in an episode of "C.S.I." in 2000. He has a large and loyal fanbase, who are said to have 'Bieber Fever' and are nicknamed 'Bielbers'. Bieber continues with a hugely successful music career.

## II. Answer the questions about Justin Bieber

1. Who is Justin Bieber? \_\_\_\_\_
2. Where was he born? \_\_\_\_\_
3. When was he born? \_\_\_\_\_
4. Where did he post his performances? \_\_\_\_\_
5. Who is his agent? \_\_\_\_\_
6. What was his first single? \_\_\_\_\_
7. When did he release his concert film "Never Say Never"? \_\_\_\_\_
8. When did he play a young killer in an episode of "C.S. I."? \_\_\_\_\_



FRIDAY: Flashcards (color, cut and paste them on cardboard. Then study).

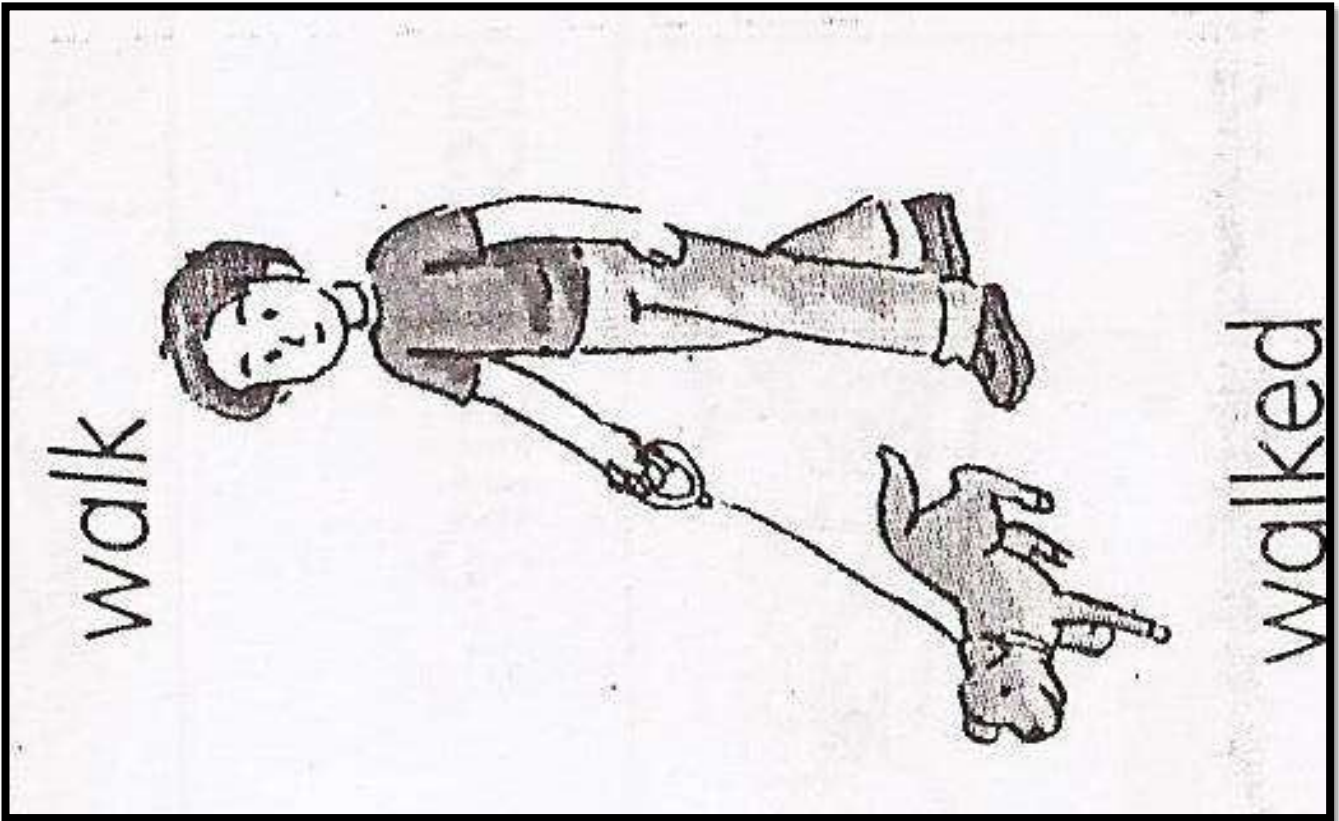
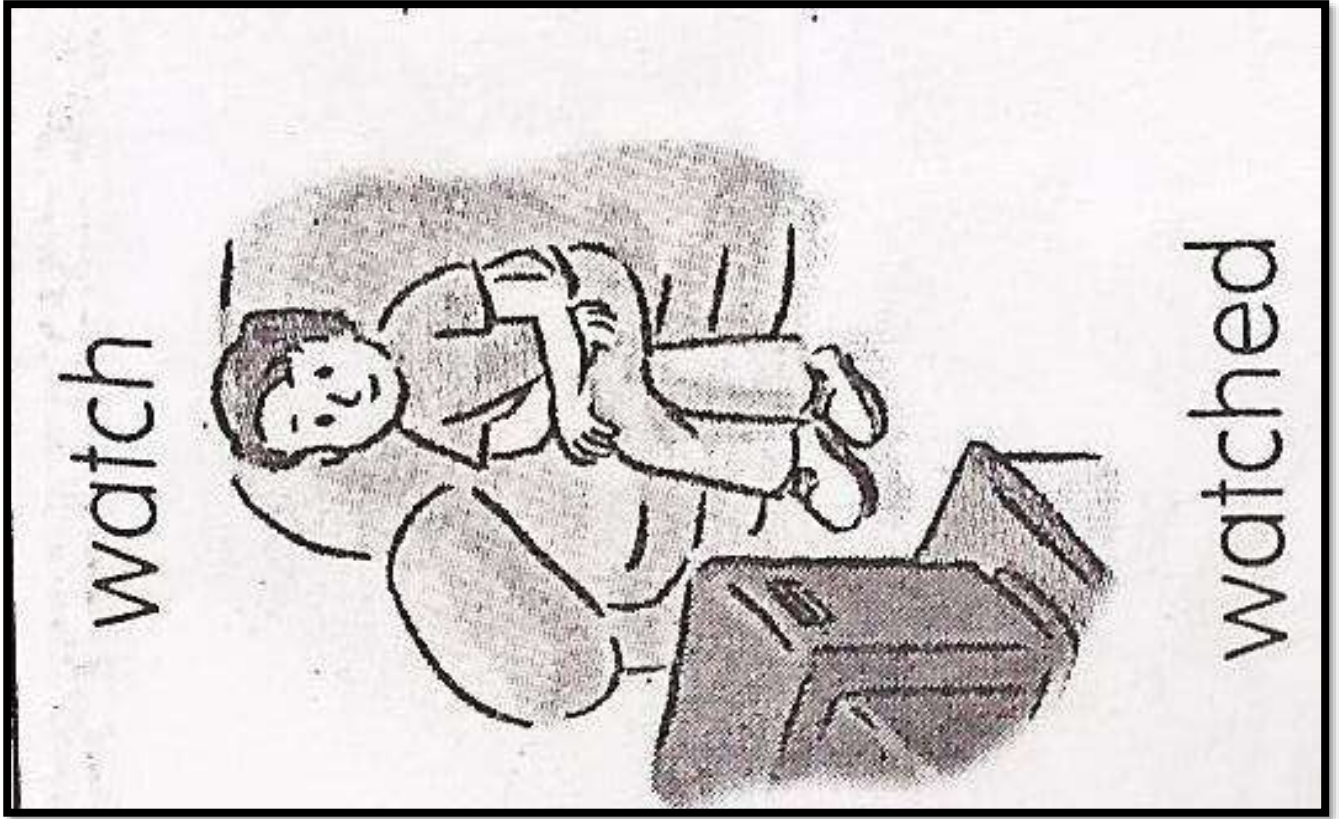

talk

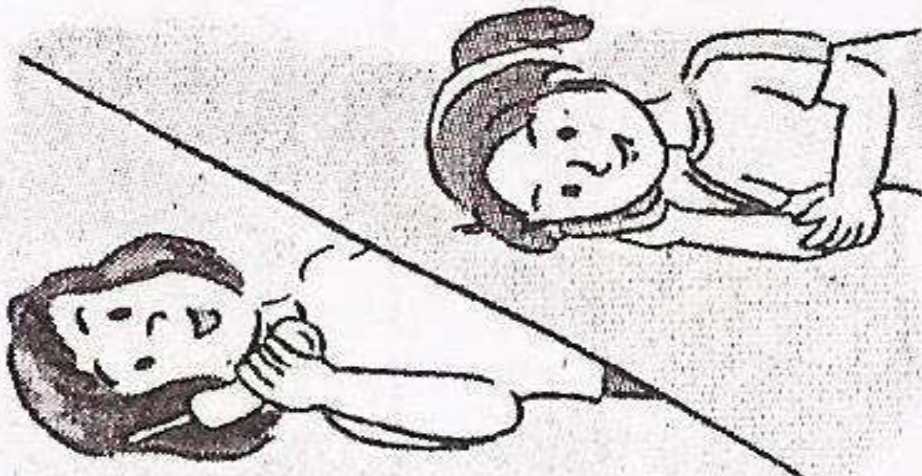

talked

visit



visited



study

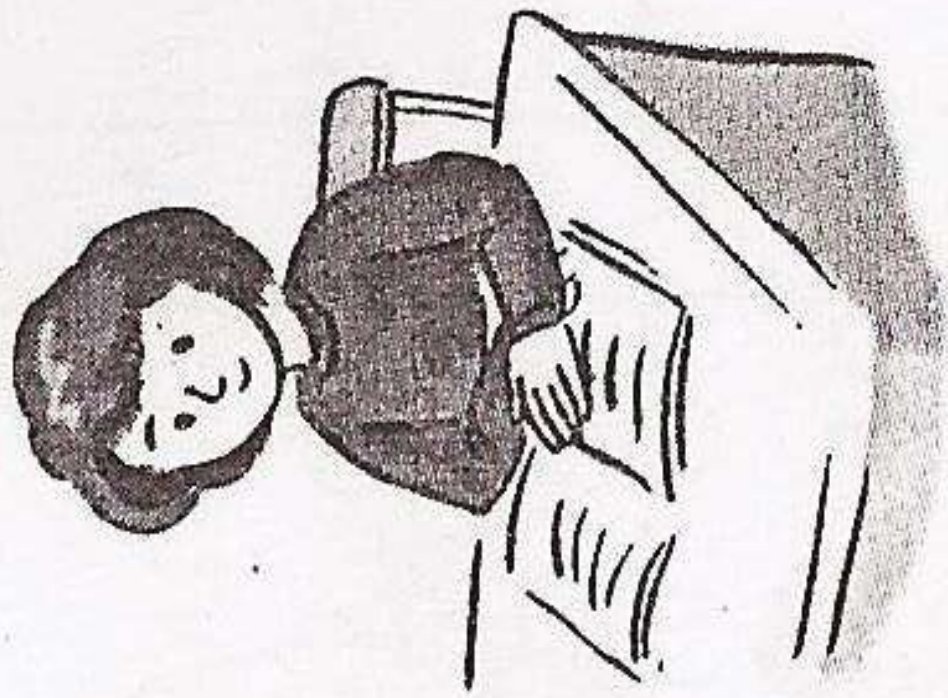

studied

play

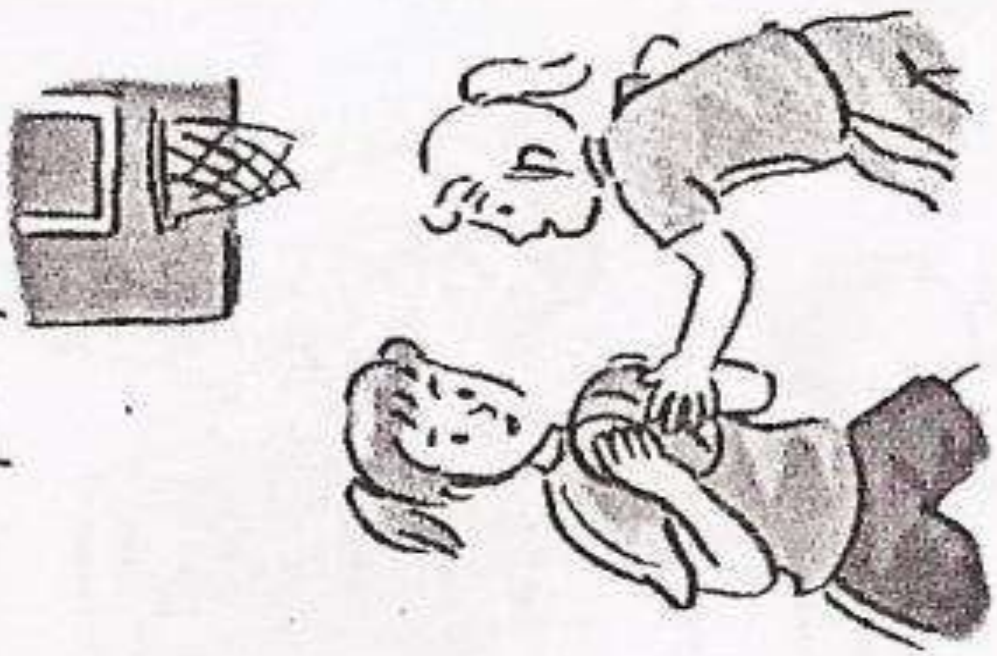

played



plant



planted

cleaned



clean

practice

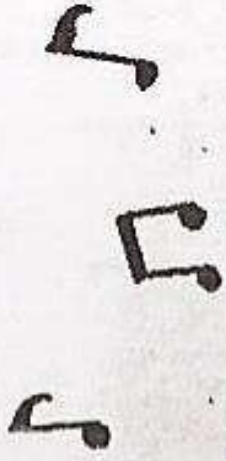

practiced

bake



baked



**Inventario de actividades de Inglés (nivel: BASIC)  
(Apoyo a la recuperación académica 2017)**

Estimado estudiante:

Te proponemos el presente inventario de actividades como un recurso de apoyo para el proceso de recuperación académica que debes seguir durante el mes de enero de 2018. Te pedimos tener presente, respecto al inventario, lo siguiente:

- Ha sido elaborado de acuerdo con un temario anual, el cual considera los cuatro bimestres (25 % c/u).
- Las actividades que se presenta en él han sido tomadas de documentos de trabajo, libros del año escolar 2017 y de otras fuentes, pero que se ajustan a los contenidos del temario anual.
- Ha sido dosificado para ser desarrollado en cuatro semanas, de lunes a viernes, destinando para ello una hora diaria aproximadamente.
- El estudiante debe imprimir los documentos que serán desarrollados, archivados y presentados en un fólder manila tamaño oficio (incluir carátula), el mismo que será revisado y evaluado por los docentes responsables de la evaluación de recuperación, asignándole un peso de 25 % en el resultado final de la recuperación como “evaluación de portafolio”. De hecho, si no lo presentases desarrollado, se te asignará la nota mínima en evaluación de portafolio.
- Si los estudiantes requiriesen presentarse a la segunda oportunidad, podrán mejorar y volver a presentarlo desarrollado, prevaleciendo, en este caso, la segunda calificación. Si no lo hiciesen, mantendrán la calificación obtenida en la primera ocasión.
- En la tabla de control diario, el padre de familia debe firmar para apoyar y controlar el avance diario del estudiante en su desarrollo.
- No hemos incluido una calendarización específica para su desarrollo (fechas de inicio y fin), asumiendo que cada estudiante lo hará en coordinación con sus padres, considerando la realidad particular y los planes de la familia. En todo caso, el trabajo ha sido previsto para cuatro semanas.
- La primera oportunidad de evaluación será a fines de enero. La presentación del portafolio (inventario desarrollado) es obligatoria desde la primera oportunidad de evaluación.

<b>SEMANA 1</b>	<b>BIMESTRE 1</b>	<b>TEMA 1</b>	<b>CLOTHING</b>	<b>Worksheet 1</b>
		<b>TEMA 2</b>	<b>SIMPLE PRESENT TENSE</b>	<b>Worksheet 2</b>
<b>SEMANA 2</b>	<b>BIMESTRE 2</b>	<b>TEMA 3</b>	<b>FAMILY MEMBERS</b>	<b>Worksheet 3</b>
		<b>TEMA 4</b>	<b>SIMPLE PAST : WAS WERE</b>	<b>Worksheet 4</b>
<b>SEMANA 3</b>	<b>BIMESTRE 3</b>	<b>TEMA 5</b>	<b>SPORTS</b>	<b>Worksheet 5</b>
		<b>TEMA 6</b>	<b>SIMPE PAST VS. PAST CONTINUOUS</b>	<b>Worksheet 6</b>
<b>SEMANA 4</b>	<b>BIMESTRE 4</b>	<b>TEMA 7</b>	<b>GEOGRAPHICAL FEATURES</b>	<b>Worksheet 7</b>
		<b>TEMA 8</b>	<b>SUPERLATIVES</b>	<b>Worksheet 8</b>

Tabla de firmas del padre de familia de control diario					
	Lunes 1 de enero	Martes 2 de enero	Miércoles 3 de enero	Jueves 4 de enero	Viernes 5 de enero
Semana 1					
	Lunes 8 de enero	Martes 9 de enero	Miércoles 10 de enero	Jueves 11 de enero	Viernes 12 de enero
Semana 2					
	Lunes 15 de enero	Martes 16 de enero	Miércoles 17 de enero	Jueves 18 de enero	Viernes 19 de enero
Semana 3					
	Lunes 22 de enero	Martes 23 de enero	Miércoles 24 de enero	Jueves 25 de enero	Viernes 26 de enero
Semana 4					

## WEEK 1

### WORKSHEET 1

#### I. Match the things with the shops.

0. shoes shoe shop
1. packet of cereal \_\_\_\_\_
2. medicine \_\_\_\_\_
3. trainers \_\_\_\_\_
4. newspaper \_\_\_\_\_
5. jeans \_\_\_\_\_

newsagent's  
sports shop  
clothes shop  
chemist's  
~~shoe shop~~  
supermarket

#### II. Complete the name of the clothes.

Example:



0. s a n d a l s



1. \_ r \_ s \_



2. B \_ \_ \_



3. S \_ \_ r \_



4. \_ a c \_ \_ \_



5. B \_ \_ \_ s



III. Write the name of the different clothes items.

0



shoes

1



2



3



4



5



## WORKSHEET 2

IV. Underline the correct verb form.

0. My friend *love* / loves ice cream.
1. Mario wash / washes his car every week.
2. We eat / eats an apple every day.
3. Max always watch / watches TV after school.
4. They do / does their homework in the evening.
5. I start / starts school at eight o'clock.
6. Nadia usually have / has lunch at school.

V. Match the questions and answers.

- 1 Does he walk to school every day?
- 2 Do you go to school by car?
- 3 Do you always watch TV on Sundays?
- 4 Do they play football on Saturdays?
- 5 Does she usually play computer games?

- a No, I don't. I walk to school.
- b Yes, they do. They're in the school team.
- c No, she doesn't. She likes reading books.
- d No, he doesn't. He goes by car.
- e Yes, I do. I like watching basketball.

**VI. Complete the text with the PRESENT SIMPLE of the verbs in brackets.**

David <sup>1</sup>..... (like) yoghurt and he <sup>2</sup>..... (eat) an apple every day.

He is healthy! He usually <sup>3</sup>..... (have) lunch in the school canteen and in the evenings, he <sup>4</sup>..... (go) running.



**VII. Underline the correct form of the verb.**

0. You don't / doesn't understand!
1. Sally don't / doesn't like oranges.
2. The children don't / doesn't watch TV in the morning.
3. I don't / doesn't take the dog for a walk every day.
4. Tom don't / doesn't read magazines.
5. We don't / doesn't eat hamburgers.

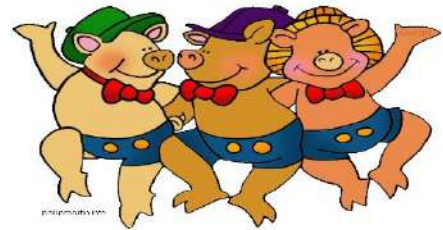

**They don't sing.**

**VIII. Rewrite the sentences in the NEGATIVE FORM.**

0. I get up at seven o'clock.  
I don't get up at seven o'clock
1. They listen to music every day.  
.....
2. Sarah goes shopping.  
.....
3. Mark plays computer game  
.....
4. You go roller skating.  
.....
5. We have breakfast at 8 o'clock.  
.....



**She doesn't love him.**

**IX. Write questions and short answers. (X = negative).**

0. Sarah / catch the bus every morning (✓)  
Does Sarah catch the bus every morning?  
Yes, she does.

1. Fred / play football in a team (X)  
 .....?  
 .....
2. Mike and Sally / go shopping on Fridays (X)  
 .....?  
 .....
3. Sarah / play the piano (✓)  
 .....?  
 .....
4. you / do your homework in the afternoon (✓)  
 .....?  
 .....



**X. Answer the questions, in a complete form, about yourself.**

1. What time do you usually get up in the morning?  
 .....
2. And what time do you usually go to bed?  
 .....
3. Do you sometimes play computer games?  
 .....

**WEEK 2**

**WORKSHEET 3**

**I. Write the name of your relatives and extended family.**

0. The parents of your parents are your GRANDPARENTS

1. The father of your father/mother. \_\_\_\_\_
2. The mother of your father/mother. \_\_\_\_\_
3. The children of your children. \_\_\_\_\_
4. The son of one of your children. \_\_\_\_\_
5. The daughter of one of your children. \_\_\_\_\_
6. The father of your grandfather/grandmother. \_\_\_\_\_
7. The mother of your grandfather/grandmother. \_\_\_\_\_



8. The brother (or brother-in-law) of your mother/father. \_\_\_\_\_
9. The sister (or sister-in-law) of your mother/father. \_\_\_\_\_
10. The child of your aunt/uncle. \_\_\_\_\_
11. The male child of your brother/sister. \_\_\_\_\_
12. The female child of your brother/sister. \_\_\_\_\_

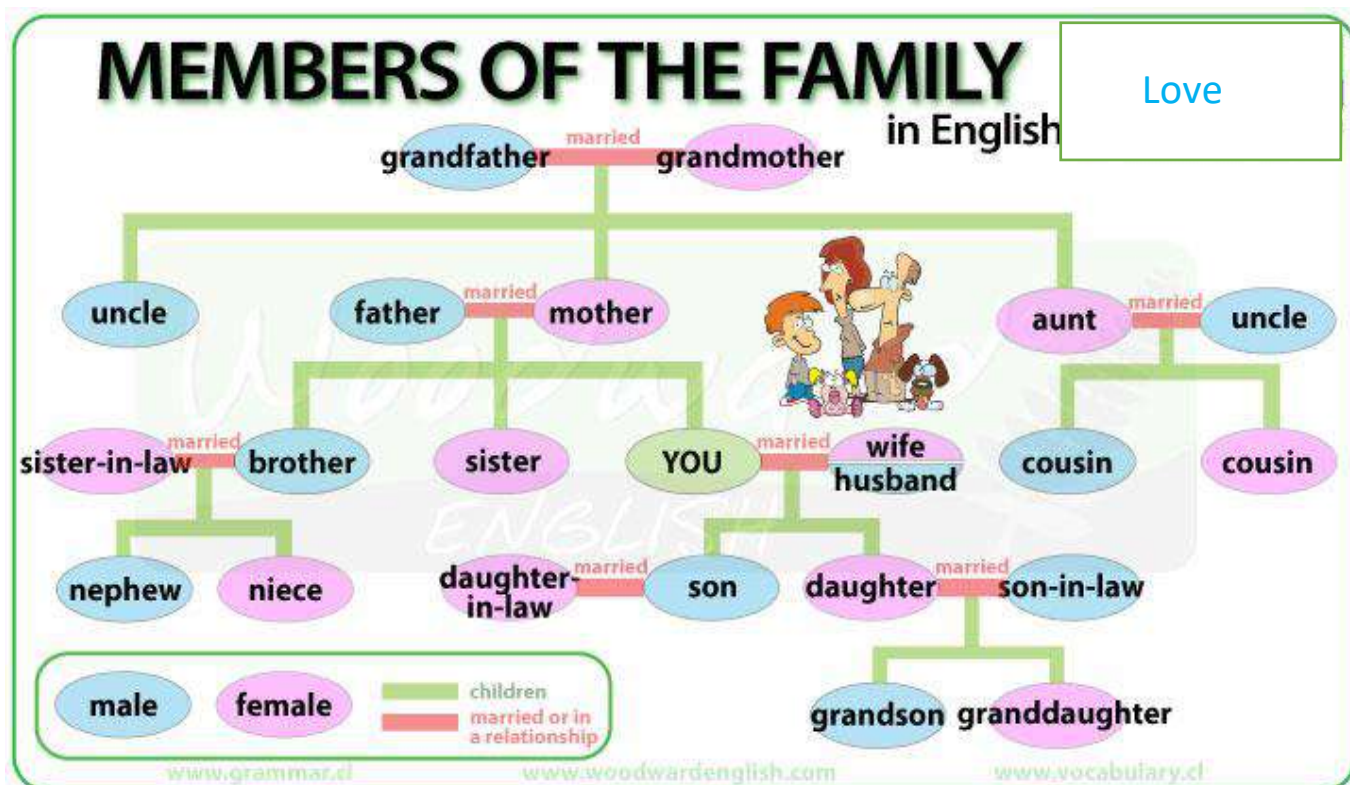

II. Complete this family tree.

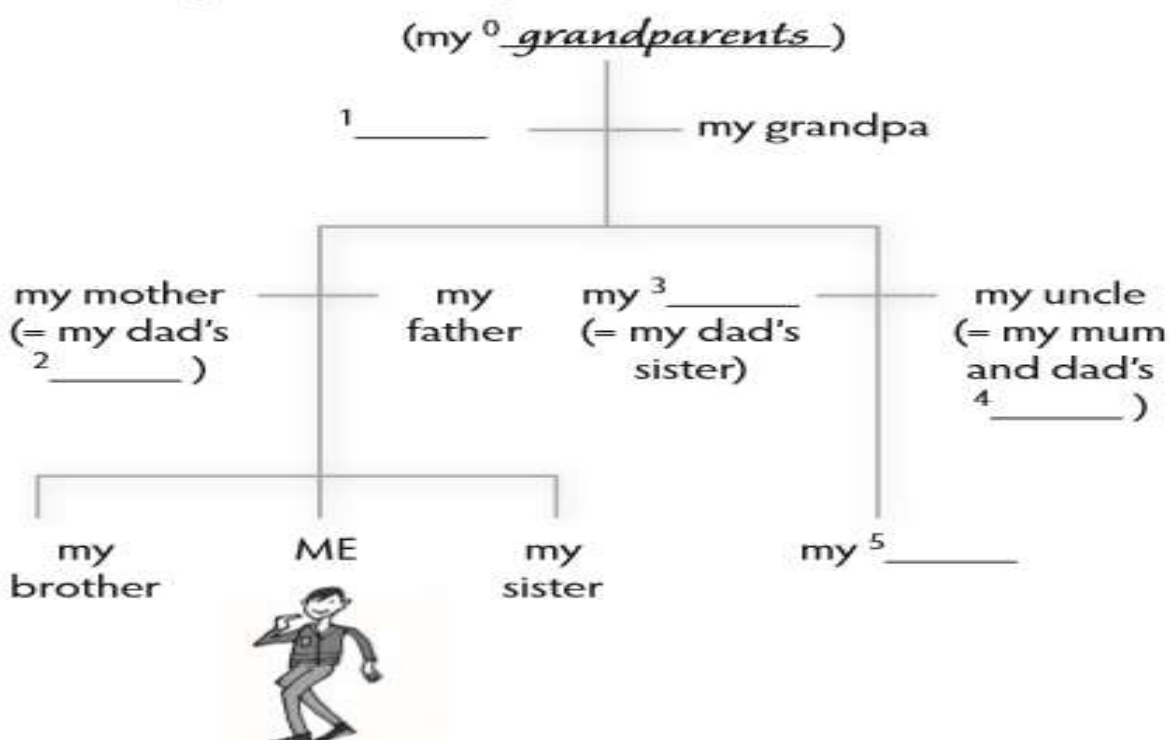



# WORKSHEET 4

III. Complete the conversations. Use the PAST SIMPLE form of TO BE.

0. A Were you at school yesterday?  
B No, I wasn't.
1. A. \_\_\_\_\_ John upset about Mary?  
B. No, he \_\_\_\_\_ .
2. A. \_\_\_\_\_ the film good?  
B. No, it \_\_\_\_\_ very boring.
3. A. \_\_\_\_\_ there many people at the museums?  
B. Yes, there \_\_\_\_\_ a lot of tourists.
4. A. Where \_\_\_\_\_ you and your brother at the weekend?  
B. We \_\_\_\_\_ at home.
5. A. \_\_\_\_\_ Pat and Sarah at Jane's party?  
B. No, they \_\_\_\_\_ .

## WAS and WERE

AFFIRMATIVE	
I	WAS
YOU	WERE
HE	} WAS
SHE	
IT	} WERE
WE	
YOU	
THEY	

NEGATIVE	
I	WASN'T
YOU	WEREN'T
HE	} WASN'T
SHE	
IT	} WEREN'T
WE	
YOU	
THEY	

INTERROGATIVE	
WAS	I ... ?
WERE	YOU ... ?
WAS	HE ... ?
	SHE ... ?
WERE	IT ... ?
	WE ... ?
	YOU ... ?
	THEY ... ?

It **was** rainy yesterday.



It **wasn't** sunny yesterday.

Was it rainy yesterday?

### 1) Underline the correct verb.

Example: We was / were at the zoo last Sunday.

- Tom **wasn't** / **weren't** at school last week.
- It **was** / **were** cold yesterday.
- My parents **wasn't** / **weren't** in Italy last year.
- Sally **was** / **were** in the country at the weekend.

- Sarah **wasn't** / **weren't** happy yesterday.
- They **was** / **were** late for school last Tuesday.
- Dave **wasn't** / **weren't** tired yesterday.
- Ted and Jill **was** / **were** at the theatre last night.

### 2) Rewrite the sentences in the past simple.

Example: I'm not at school. I **wasn't** at school.

- Mark isn't here. \_\_\_\_\_
- This dog is funny. \_\_\_\_\_
- I am not busy. \_\_\_\_\_
- You are very lucky. \_\_\_\_\_
- The winter is cold. \_\_\_\_\_
- They aren't tired. \_\_\_\_\_
- We are hungry. \_\_\_\_\_
- This book isn't boring. \_\_\_\_\_

**3) Make questions with the following words.  
Write the answers to the questions.**

**Example:** you / at the zoo / yesterday / were  
Were you at the zoo yesterday? Yes, I was.

1. you / at the party / two days ago / were

No, I \_\_\_\_\_

2. the shops / open / were / last Sunday

Yes, they \_\_\_\_\_

3. Sam / last week / was / at the museum

Yes, he \_\_\_\_\_

4. at the sports centre / they / last Monday / were

No, they \_\_\_\_\_

5. sick / yesterday / were / Sally and her sister

Yes, they \_\_\_\_\_

6. the weather / cold and wet / was / last Tuesday

No, it \_\_\_\_\_

7. in London / Jane / last year / was

Yes, she \_\_\_\_\_

**4) Complete the questions with was and were**

**Example:**

***Was it*** cold yesterday?

Yes, it was.

1.

\_\_\_\_\_ at the cinema last night?

2.

\_\_\_\_\_ at home  
yesterday?

No, they weren't.  
Adam and Ann  
weren't at the  
cinema last night.

3.

\_\_\_\_\_ at Paul's  
birthday party last  
Saturday?

Yes, I was.

4.

\_\_\_\_\_ your  
birthday last  
Monday?

Yes, she was.  
Mary was there.

No, it wasn't. It  
was my brother's  
birthday last  
Monday.





## WEEK 3

### Worksheet 6

I. Complete the following text using the PAST TENSE of the verbs in brackets.

Anna's holiday \_\_\_\_\_ (be) great last summer. She \_\_\_\_\_ (stay) in a college in England for two weeks. She \_\_\_\_\_ (have) classes in the mornings and in the afternoons she \_\_\_\_\_ (do) some sports like swimming or tennis. In the evenings she often \_\_\_\_\_ (go) dancing or \_\_\_\_\_ (watch) films with her new friends.

At weekends they \_\_\_\_\_ (drive) to some interesting places. Once they \_\_\_\_\_ (visit) Marwell Zoo where they \_\_\_\_\_ (see) some beautiful animals. Anna \_\_\_\_\_ (not like) the food at the college but that \_\_\_\_\_ (not be) a problem. She \_\_\_\_\_ (meet) a lot of people and \_\_\_\_\_ (learn) some English. All the students in her class \_\_\_\_\_ (be) sorry to go home. They all \_\_\_\_\_ (promise) to come back next summer.

II. Here are the things Anna wanted to do last weekend. She didn't do all of them. Write what she did or didn't do.

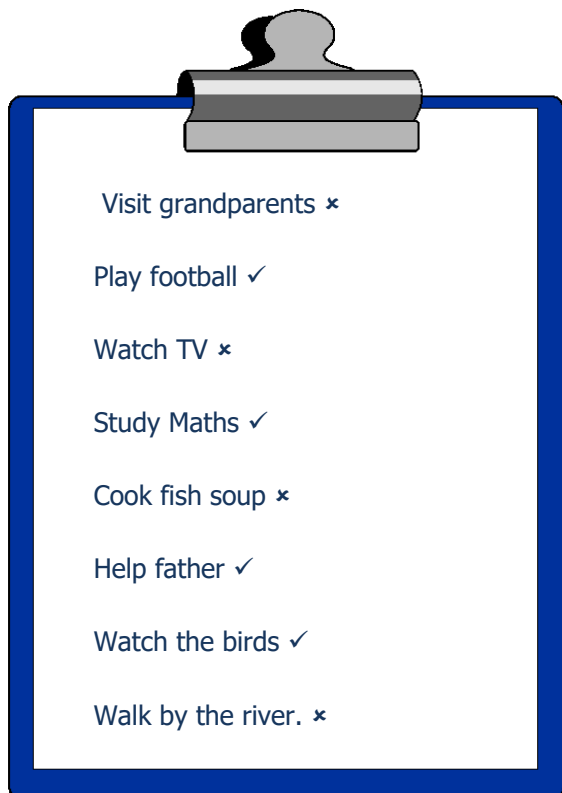

1. She didn't visit her grandparents.
2. \_\_\_\_\_
3. \_\_\_\_\_
4. \_\_\_\_\_
5. \_\_\_\_\_
6. \_\_\_\_\_
7. \_\_\_\_\_
8. \_\_\_\_\_

**III. Put the verbs into the correct form. Use PAST CONTINUOUS structures.**

1. When I phoned my friends, they (play) **were playing** monopoly.
2. Yesterday at six I (prepare) \_\_\_\_\_ dinner.
3. The kids (play) \_\_\_\_\_ in the garden when it suddenly began to rain.
4. I (practice) \_\_\_\_\_ the guitar when he came home.
5. We (not / cycle) \_\_\_\_\_ all day.
6. While Alan (work) \_\_\_\_\_ in his room, his friends (swim) in the pool.
7. I tried to tell them the truth but they (not / listen) \_\_\_\_\_
8. What (you / do) \_\_\_\_\_ yesterday?
9. Most of the time we (sit) \_\_\_\_\_ in the park.
10. I (listen) \_\_\_\_\_ to the radio while my sister (watch) TV.
11. When I arrived, They (play) \_\_\_\_\_ cards.
12. We (study) \_\_\_\_\_ English yesterday at 4:00 pm.

**IV. Fill in the blanks with a correct form. Use PAST SIMPLE or PAST CONTINUOUS structures.**

1. We **were playing** (play) volleyball with Mary, when you **called** (call) me.
2. When the teacher \_\_\_\_\_ (come) in, they \_\_\_\_\_ (study) English.
3. The baby \_\_\_\_\_ (sleep) when the telephone \_\_\_\_\_ (ring).
4. As I \_\_\_\_\_ (walk) in the streets of Holland, I \_\_\_\_\_ (meet) an old friend of mine.
5. My neighbor (meet) \_\_\_\_\_ her husband while she (travel) \_\_\_\_\_ around Catalonia.
6. I \_\_\_\_\_ (look) for my purse when I \_\_\_\_\_ (drop) my credit card.
7. Shakira (sing) \_\_\_\_\_ in a concert when she (lose) \_\_\_\_\_ her voice.
8. While I (have) \_\_\_\_\_ a shower, the lights (go out) \_\_\_\_\_.
9. We (drive) \_\_\_\_\_ to the hospital when the baby (be born) \_\_\_\_\_.
10. My mother (lose) \_\_\_\_\_ her purse when she (walk) \_\_\_\_\_ home.



# WEEK 4

## Worksheet 7

## Worksheet 8

### I. Complete with a superlative adjective and all the necessary words.

1. London is ..... (large) city in England.
2. Cheetahs are ..... (fast) animals in the world.
3. Whales are ..... (big) animals.
4. San Francisco is ..... (beautiful) city in the United States.
5. Summer is .....(good) season of the year.

### II. Write the superlative form.

- |                    |                     |
|--------------------|---------------------|
| 1. good .....      | 6. pretty .....     |
| 2. far .....       | 7. small .....      |
| 3. expensive ..... | 8. nice .....       |
| 4. old .....       | 9. comfortable..... |
| 5. young .....     | 10. bad .....       |

### III. Look at the information in the picture. Write 10 sentences using SUPERLATIVE adjectives.



**Example:**

Tom is the oldest in the group.

1. \_\_\_\_\_.
2. \_\_\_\_\_.
3. \_\_\_\_\_.
4. \_\_\_\_\_.
5. \_\_\_\_\_.
6. \_\_\_\_\_.
7. \_\_\_\_\_.
8. \_\_\_\_\_.
9. \_\_\_\_\_.
10. \_\_\_\_\_.





**Inventario de actividades de Inglés (nivel: INTERMEDIATE)  
(Apoyo a la recuperación académica 2017)**

Estimado estudiante:

Te proponemos el presente inventario de actividades como un recurso de apoyo para el proceso de recuperación académica que debes seguir durante el mes de enero de 2018. Te pedimos tener presente, respecto al inventario, lo siguiente:

- Ha sido elaborado de acuerdo con un temario anual, el cual considera los cuatro bimestres (25 % c/u).
- Las actividades que se presenta en él han sido tomadas de documentos de trabajo, libros del año escolar 2017 y de otras fuentes, pero que se ajustan a los contenidos del temario anual.
- Ha sido dosificado para ser desarrollado en cuatro semanas, de lunes a viernes, destinando para ello una hora diaria aproximadamente.
- El estudiante debe imprimir los documentos que serán desarrollados, archivados y presentados en un fólter manila tamaño oficio (incluir carátula), el mismo que será revisado y evaluado por los docentes responsables de la evaluación de recuperación, asignándole un peso de 25 % en el resultado final de la recuperación como “evaluación de portafolio”. De hecho, si no lo presentases desarrollado, se te asignará la nota mínima en evaluación de portafolio.
- Si los estudiantes requiriesen presentarse a la segunda oportunidad, podrán mejorar y volver a presentarlo desarrollado, prevaleciendo, en este caso, la segunda calificación. Si no lo hiciesen, mantendrán la calificación obtenida en la primera ocasión.
- En la tabla de control diario, el padre de familia debe firmar para apoyar y controlar el avance diario del estudiante en su desarrollo.
- No hemos incluido una calendarización específica para su desarrollo (fechas de inicio y fin), asumiendo que cada estudiante lo hará en coordinación con sus padres, considerando la realidad particular y los planes de la familia. En todo caso, el trabajo ha sido previsto para cuatro semanas.
- La primera oportunidad de evaluación será a fines de enero. La presentación del portafolio (inventario desarrollado) es obligatoria desde la primera oportunidad de evaluación.

**Semana 1**

**Bimestre 1**

**UNIT 3 THAT’S ENTERTAINMENT**

**GRAMMAR: Comparative and Superlative Adjectives; (not) as ... as; Adverbs; making a comparison stronger or weaker.**

**VOCABULARY: Types of films, TV programs; expressions with GET**

**Semana 2**

**Bimestre 2**

**UNIT 6 MAKING A DIFFERENCE**

**GRAMMAR: Will (not) May (not), Might (not), First Conditional**

**VOCABULARY: The environment; verbs to talk about energy**

**Semana 3**

**Bimestre 3**

**UNIT 8 SCIENCE COUNTS**

**GRAMMAR: past simple vs past continuous; used to; Second conditional; I wish**

**VOCABULARY: direction and movement; science**



**Semana 4****Bimestre 4****UNIT 9 -10 WHAT A JOB! - KEEP HEALTHY**

**GRAMMAR:** Passive voice (present simple and past simple, present perfect and present continuous); Past Perfect vs Past Perfect Continuous

**VOCABULARY:** Jobs; work as/ in/ for vs job; time expression with *in*; Time linkers; illness collocations.

	Tabla de firmas del padre de familia de control diario				
	Lunes 1 de enero	Martes 2 de enero	Miércoles 3 de enero	Jueves 4 de enero	Viernes 5 de enero
Semana 1					
	Lunes 8 de enero	Martes 9 de enero	Miércoles 10 de enero	Jueves 11 de enero	Viernes 12 de enero
Semana 2					
	Lunes 15 de enero	Martes 16 de enero	Miércoles 17 de enero	Jueves 18 de enero	Viernes 19 de enero
Semana 3					
	Lunes 22 de enero	Martes 23 de enero	Miércoles 24 de enero	Jueves 25 de enero	Viernes 26 de enero
Semana 4					

**ANEXOS**



# INGLÉS

## INTERMEDIO

### INVENTARIO DE EJERCICIOS, PROBLEMAS Y ACTIVIDADES – APOYO A LA RECUPERACIÓN ACADÉMICA 2017

Docentes responsables: - JORGE RAFAEL PAREDES SANCHEZ

- REBECA PEREZ ACEVEDO

## Anexo 1

## BIM I

### Monday

### Week 1

#### I. Read the sentences. Write **S** if they have the same meaning and **D** if the meaning is different.

- 0 I'm not as clever as you. / You are more intelligent than me. S
- 1 My son is younger than yours. / My son isn't as old as yours. \_\_\_\_
- 2 Cats are more independent than dogs. / Dogs aren't as independent as cats. \_\_\_\_
- 3 I'm not as clever as you. / You are more intelligent than me. \_\_\_\_
- 4 My son is younger than yours. / My son isn't as old as yours. \_\_\_\_
- 5 Cats are more independent than dogs. / Dogs aren't as independent as cats. \_\_\_\_

#### II. Match the film descriptions to the films.

- |   |                    |
|---|--------------------|
| 1. ____ A film which tells real life stories,<br>especially about animals and places. | A. Documentary     |
| 2. ____ A film which combines comedy and love stories.                                | B. Thriller        |
| 3. ____ A film where frightening things happen and you feel scared.                   | C. Horror film     |
| 4. ____ A film that it's often about solving a crime.                                 | D. Romantic comedy |

#### III. Complete the sentences with adjectives.

1. Mum gets up \_\_\_\_\_ Dad in the morning. She gets up \_\_\_\_\_ (early)
2. I do my homework \_\_\_\_\_ my brother. I am more \_\_\_\_\_ him (careful)
3. Tia studies \_\_\_\_\_ for her exams than me. (hard)
4. Grandma drives \_\_\_\_\_ at night. She drives \_\_\_\_\_ Granddad (slow)

# Tuesday

## I. Complete the sentences with *as...as/notas... as* so with your ideas. Use the words in the list.

enjoyable | delicious | ~~difficult~~ interesting | relaxing | exciting

0. English is not as difficult as Maths.
1. Horror films are \_\_\_\_\_ action films.
2. Sports programmes are \_\_\_\_\_ reality shows.
3. A film is \_\_\_\_\_ a TV programme.
4. A play is \_\_\_\_\_ a concert.

## II. Write the correct television programmes.

- TOM** I got really excited when my team scored a goal quite at the end of the match. sports programmes
- YAZ** I knew all the answers! g\_\_\_\_\_ s\_\_\_\_\_
- ANA** Have you seen the latest episode? It was really funny. s\_\_\_\_\_
- JOE** Zane was voted off the show yesterday. r\_\_\_\_\_ s\_\_\_\_\_
- LUCIA** I think Rebecca Jones sings beautifully; she should be the winner. t\_\_\_\_\_ s\_\_\_\_\_
- TOBY** I watched *Tom and Jerry* yesterday and I laughed a lot. c\_\_\_\_\_

## III. Complete the text. Use the correct comparative or superlative form of the adjectives.



www.reviews.uk

### MOVIE REVIEWS .....

*Spaceman 2* is the <sup>0</sup> best (good) new sci-fi/action film for a long time. The special effects in this film are <sup>1</sup> \_\_\_\_\_ (good) *Spaceman 1* and the story is <sup>2</sup> \_\_\_\_\_ (interesting). But, the film was <sup>3</sup> \_\_\_\_\_ (expensive) *Spaceman 1* to make – it cost \$250 million. Many people thought that *Spaceman 1* was the <sup>4</sup> \_\_\_\_\_ (bad) film ever made but I think this <sup>5</sup> \_\_\_\_\_ (late) film is a bit better.



# Wednesday

**I. Write adverbs**

- |                  |               |
|------------------|---------------|
| 1. Careful _____ | 5. Bad _____  |
| 2. Clever _____  | 6. Easy _____ |
| 3. Clear _____   | 7. Fast _____ |
| 4. Good _____    | 8. Slow _____ |

**II. Fill in the blanks with the correct form of the adjectives in brackets**

1. The weather this summer is \_\_\_\_\_ (hot) last summer.
2. Football is \_\_\_\_\_ (popular) sport in the world.
3. Cheetahs are \_\_\_\_\_ (fast) lions or tigers. In fact, they are \_\_\_\_\_ (fast) animals in the world.
4. He is \_\_\_\_\_ (bad) cook I have ever met.
5. Alan is \_\_\_\_\_ (tall) Clive and Brett, but Brett is \_\_\_\_\_ (fat) of the three.

**III. Complete the table.**

Adjective	Comparative	Superlative
big	bigger	0 <i>the biggest</i>
1 _____	taller	2 _____
3 _____	4 _____	the prettiest
expensive	5 _____	6 _____
7 _____	more interesting	8 _____
9 _____	10 _____	the most difficult
good	11 _____	12 _____
13 _____	worse	14 _____

## I. Read the entertainment guide. Match.

- |                         |       |   |
|-------------------------|-------|---|
| 0 Today                 | _____ | b |
| 1 Police Detectives     | _____ |   |
| 2 The \$1,000,000 Quiz  | _____ |   |
| 3 Star in My Car        | _____ |   |
| 4 The Sound             | _____ |   |
| 5 Nutty Antiques        | _____ |   |
| 6 I Want to Go Home!    | _____ |   |
| 7 Old Bernard's Balloon | _____ |   |

- a talent show
- b news
- c reality show
- d drama series
- e sitcom
- f talk show
- g cartoon
- h game show

## II. Read the entertainment guide again. Mark these sentences T (true), F (false), or DS (doesn't say).

- 1 Today is a comedy show about the news.   T
- 2 In Police Detectives, two police officers make jokes.
- 3 The questions are very difficult on The \$1,000,000 Quiz.
- 4 Star in My Car isn't as interesting as other talk shows.
- 5 Many singers who are famous now won The Sound.
- 6 Nutty Antiques isn't as funny as other sitcoms.
- 7 The celebrities on I Want to Go Home! often disagree with each other.
- 8 The presenter in Old Bernard's Balloon is not animated

## III. Complete the sentences with your own ideas. Use *a lot, much, far, a little, a bit*.

0. Action films are much better than thrillers.
1. Game shows \_\_\_\_\_ reality shows.
2. A concert \_\_\_\_\_ a play
3. Staying in a hotel \_\_\_\_\_.
4. History \_\_\_\_\_ Geography.
5. Classical music \_\_\_\_\_ rock music.

These days, you can easily watch TV online. Not everything's good, of course, but here are our recommendations. ✕

**LIKE • COMMENT • SHARE**

---

**Today**

A look at what's in the news around the world.

---

**Police Detectives**

This exciting new show is about two police officers in Chicago. They investigate crimes and catch criminals.

---

**The \$1,000,000 Quiz**

No one has won the big million-dollar prize yet, perhaps because the host, Nick Parsons, asks the most complicated questions on TV. Most contestants leave with nothing.

---

**Star in My Car**

Neil Smith drives around Los Angeles in a big car. Inside is a camera and a celebrity! They sing along to the radio. It's not as boring as it sounds. Neil asks much more interesting questions than other presenters ask.

---

**The Sound**

Every week, contestants get the chance to sing in front of celebrity singers. Some contestants have a lot of talent – but many don't. The winner of the show gets a recording contract.

---

**Nutty Antiques**

This comedy is about a group of people who work in a store, selling old furniture. It's far funnier than anything else on TV. The best character is Mrs. Macaroon, the cleaner, who breaks everything.

---

**I Want to Go Home!**

Ten celebrities are on an island in the middle of nowhere with no electricity and no phones! They have to find their own food and cook it. It's great to see them argue – and they often do! All the celebrities want to go home, but you can go online and vote for the celebrity you want to keep on the island!

---

**Old Bernard's Balloon**

This is easily the best kid's show on TV. Bernard tells stories about how he flies around in a balloon, meeting his friends Russell the dragon and Jack the parrot. It's beautifully animated.



IV. Rewrite the sentences so that they have the same meaning.

- 0. Tom is a bad cook compared to you. (much)  
You are a much better cook than Tom.
- 1. Chips are healthier than vegetables. (far)  
Vegetables \_\_\_\_\_.
- 2. This film is definitely more boring than the book. (a lot)  
The book \_\_\_\_\_.
- 3. It is cloudier today than it was yesterday. (a bit)  
The weather \_\_\_\_\_.
- 4. My tablet is a lot newer than your computer. (much)  
Your computer \_\_\_\_\_.
- 5. Mary is 1.37m and Tia is 1.35m. (a bit)  
Tia \_\_\_\_\_.

**COMPARATIVES - CROSSWORD**

LOOK AT THE PICTURES AND FILL IN THE CROSSWORD PUZZLE. USE THE COMPARATIVE.

1. COLD      2. HOT      4. PROUD

3. MILD      5. FAST

6. SLOW

7. FAT

8. THIN

9. HAPPY      12. SHY      10. HEAVY

11. ANGRY

THE HIDDEN WORD IS \_\_\_\_\_





**Friday**

I. Cut the questions. Paste in an extra paper and answer each of them.

## 16 Question Strips

### FIRST CONDITIONAL



- What will you do ***if you can't sleep tonight?***
- ***If your TV breaks next week,*** what will you do?
- How will you feel ***if you fail your next test?***
- ***If you get lots of homework,*** how will you feel?
- What will your teacher say ***if you are late tomorrow?***
- ***If you feel bored next Saturday,*** what will you do?
- What will you eat ***if you are hungry at midnight tonight?***
- ***If you want to relax after class,*** what will you watch on TV?
- What medicine will you take ***if you catch a cold next week?***
- ***If you decide to eat out,*** which restaurant will you go to?
- When will you go to bed ***if you are really tired tonight?***
- ***If you don't eat breakfast tomorrow,*** will you feel hungry?
- Will you ask our teacher for help ***if you have a question?***
- ***If you have some free time on Saturday,*** will you study more?
- Will you get a cat ***if you decide to get a new pet?***
- ***If it rains tomorrow,*** will you bring an umbrella?



**II. Use the phrases from the list to complete each sentence.**

0. Can I get you something to eat?
1. If I \_\_\_\_\_, I want to visit Argentina when I'm in South America.
2. He \_\_\_\_\_ when his soccer team wins.
3. Her driving \_\_\_\_\_ since she passed her driving test.
4. I \_\_\_\_\_ really late yesterday.
5. I'm late! I need to \_\_\_\_\_ to class.

Get	(you)
something	
get the chance	
get home	
get back	
get excited	
get better	

**III. Circle the correct words.**

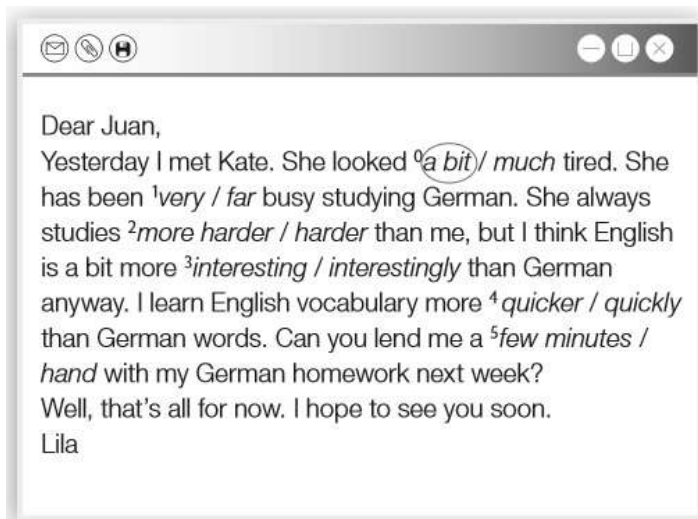

**Anexo 2**

**Monday**

**BIM II**

**Week 2**

**I. Circle the correct words**

1. An increase in the amount of gases in the atmosphere may be the cause of *deforestation* / *global warming* / *litter*.
2. We are not doing enough to protect the environment from endangered species / pollution / threat.
3. To protect the world's resources we shouldn't waste / litter / melt water and electricity.
4. A lot of rain can cause terrible smog / litter / floods.
5. Dinosaurs live only in films, they are an *endangered* / *extinct* / *waste* species.





ii. Complete the sentences. Use the first conditional of the verbs.

- Unless you \_\_\_\_\_ (be) in a hurry, we \_\_\_\_\_ (walk) to the station.
- You \_\_\_\_\_ (not feel) ill if you \_\_\_\_\_ (not eat) so many sweets.
- \_\_\_\_\_ (you / look after) my dog if \_\_\_\_\_ (go) on holiday.
- We \_\_\_\_\_ (arrive) at 10.00 unless our train \_\_\_\_\_ (be) late.
- If you \_\_\_\_\_ (lend) me the money, I \_\_\_\_\_ (come) to the concert.

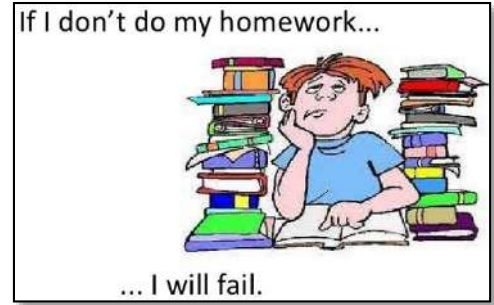

iii. Rewrite the sentences. Use *unless* and keep the same meaning.

- If you don't eat breakfast, you'll be hungry.  
\_\_\_\_\_.
- Dad won't let you go out if don't apologize.  
\_\_\_\_\_.
- If we don't save energy, we'll run out.  
\_\_\_\_\_.
- If she doesn't pass the exam, she won't go to university.  
\_\_\_\_\_.
- I'll go out on Friday if I don't have homework.  
\_\_\_\_\_.
- Don't interrupt me if you don't want to be rude.  
\_\_\_\_\_.



Tuesday

i. Write sentences. Use will or might / may.

- not / pass his driving test (certainty)  
\_\_\_\_\_.



2. visit my cousin / in France (possibility)

\_\_\_\_\_.

3. not / rain later / blue sky (possibility)

\_\_\_\_\_.

4. be / food at the party (certainly)

\_\_\_\_\_.

5. see / you later (certainly)

\_\_\_\_\_.

**II. Find and correct the mistakes in each sentence.**

0. I may not to finish this homework.

I may not finish this homework.

1. May you be at the party?

\_\_\_\_\_.

2. She'll be late unless she will leave now.

\_\_\_\_\_.

3. If he won't see me, I'll shout.

\_\_\_\_\_.

4. If he doesn't call, what do you do?

\_\_\_\_\_.

5. They might to buy me a present.

\_\_\_\_\_.

**III. Complete the sentences with WILL or WON'T**

0. This is a present for mum. I'm sure she will like it.
1. If there are no rules to reduce overfishing, more fish \_\_\_\_\_ definitely disappear forever.
2. My parents left yesterday for a two-week holiday, so they \_\_\_\_\_ be here tomorrow.
3. Come back early or you \_\_\_\_\_ get up on time.
4. If we do not protect rhinos, we \_\_\_\_\_ see any of them in the near future.
5. Do you think people \_\_\_\_\_ live on other planets in the future?



## Wednesday

### I. Read the article

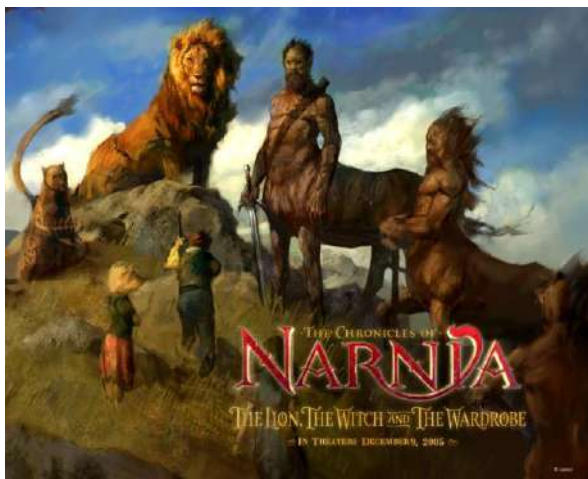

**The Lion, the Witch and the Wardrobe** tells the story of the Pevensie children – Peter, Susan, Edmund and Lucy – and their first adventures in the magical land of Narnia. The story begins during World War II in England. Because of the bombs in London, the children have to go and stay with their strange uncle in the country. The house he lives in is much bigger than their home in London, with many empty rooms. There is a big old wardrobe in

one of the rooms. While they are playing a game of hide-and-seek, Lucy, the youngest Pevensie, hides inside the wardrobe. She discovers that it isn't a normal wardrobe at all. It is a door to a snowy place in a forest. The place is silent and deserted and, the strangest thing of all, there is a lamp post in the middle of the trees. Lucy tells her brothers and sister about her adventure, and soon all four Pevensie children travel through the wardrobe to the land on the other side. They discover it is called Narnia and it is a magical place with talking animals and other strange creatures. It is cold and snowy because a witch's spell makes it endless winter. Because of a Narnian story/legend about four children who come from another land to help the Narnians, the four children become the kings and queens of the land. They have to lead a fight against the evil forces that are controlling Narnia. With the help of Aslan, a talking lion and the most powerful creature in the land, they win the fight against the witch and her evil creatures. Spring returns to Narnia, and it is a happy place again. Unfortunately, the Pevensies have to return to the "real" world and leave their new friends behind. But all four agree that discovering Narnia is the most amazing experience of their lives.

### II. Underline the correct choice.

1. The children go to the country because of the weather / the war.
2. There are three / four Pevensie children.



3. The children play hide-and-seeK in the house / the woods.
4. The wardrobe leads to another house / land.
5. It is always winter in Narnia because of a witch / the children.
6. The children become soldiers / rulers in Narnia.
7. Aslan is a lion / a man.
8. The witch and her creatures win / lose the fight against the Narnians.

**III. Complete the story outline. Use one or two words.**

The Pevensie children go from (1) \_\_\_\_\_ to the country during (2) \_\_\_\_\_. They stay in (3) \_\_\_\_\_ house. It has many (4) \_\_\_\_\_. During a game of hide and seek, the (5) \_\_\_\_\_ Pevensie discovers a wardrobe that is really a (6) \_\_\_\_\_ to a place called Narnia. The four Pevensies become (7) \_\_\_\_\_ and queens of Narnia and they lead the fight against an evil witch. In the end they (8) \_\_\_\_\_ the fight.

**IV. Answer the questions. Use complete sentences.**

1. Why do the Pevensie children go from London to the country?

\_\_\_\_\_

2. Who do they stay with?

\_\_\_\_\_

3. What are they doing when they find the wardrobe?

\_\_\_\_\_

4. What is the name of the magical place behind the wardrobe?

\_\_\_\_\_

5. What makes it a magical place?

\_\_\_\_\_

6. What do the Pevensies become there?

\_\_\_\_\_

7. What do they have to do there?

\_\_\_\_\_

8. Who helps them?

\_\_\_\_\_

9. What is the result of their effort?

\_\_\_\_\_



10. Where do they go in

# Thursday

### I. Match the parts of the conversation.

- 0. Why don't you disconnect your mobile  a
- 1. You should reuse cans, \_\_\_\_\_
- 2. Leaving things on standby is \_\_\_\_\_
- 3. My mobile battery is getting old. \_\_\_\_\_
- 4. It is possible to recycle glass \_\_\_\_\_
- 5. If you keep lights on all night, \_\_\_\_\_

- a. ~~when you aren't using it?~~
- b. I need to charge it twice a day.
- c. they make good pen holders for your desk!
- d. a waste of energy
- e. into bottles, jars and also bricks.
- f. you'll waste a lot of energy

### II. Complete the text with the words in the list.

saving	<del>global warming</del>	rubbish
melt	extinct	laws

~~Global warming~~ is a problem for all of us. Our environment is important and if we don't look after it, the polar ice caps will \_\_\_\_\_ and animals will become \_\_\_\_\_ because they won't have homes. In many countries there are \_\_\_\_\_ to protect animals and the environment but we can also help by \_\_\_\_\_ energy and recycling our \_\_\_\_\_

### III. Circle the correct words.

- 0. 'What about the weather tomorrow?'  
' I don't know, it *will* / *may* rain'.
- 1. 'Can you give Tom a message?'  
'I don't think I *will* / *might* see him tonight'
- 2. 'Are you coming to the party next Saturday?'  
'I'm not sure. I *will* / *might* not be here'.



3. *We'll / We might* be at home. Come over in the afternoon and I'll show you the photos of my holiday.
4. I'm sure Mary *will / might* win the music competition – she's been practicing a lot and she plays really well.
5. It's not easy to choose a present for someone you don't know well. They *won't / mightn't* like it.

**IV. Complete the sentences. Use the *First Conditional* of the verbs.**

0. Mary won't go (not go) on the school trip if she isn't well.
1. \_\_\_\_\_ you \_\_\_\_\_ (give) Jane my message if you see her?
2. If we \_\_\_\_\_ (not use) cars, cities won't be so polluted.
3. If we \_\_\_\_\_ (not learn) to recycle properly, we will have problems in the future.
4. If you \_\_\_\_\_ (use) a glass of water when you brush your teeth, you'll save a lot of water.
5. What \_\_\_\_\_ (happen) if they keep cutting trees?

**Friday**

**Count on me (Bruno Mars)**

**I. Listen to the song. Complete the definitions with the right words.**

stuck - find out - mean to - in need - toss and turn - count on

1. If you \_\_\_\_\_, you keep moving around in bed and cannot sleep properly, for example because you are ill or worried.
2. If you \_\_\_\_\_ something \_\_\_\_\_, you learn something that you did not already know, especially by making a deliberate effort to do so.
3. If you \_\_\_\_\_ someone you rely on them to support you or help you.
4. If something \_\_\_\_\_ something \_\_\_\_\_ you, it is important to you in some way.
5. If someone is \_\_\_\_\_, he/she is in a difficult situation.
6. If you are \_\_\_\_\_ you are unable to escape from a bad or boring situation.



II. Complete the sentences with the correct form of the verbs and the words or phrases represented by the pictures.

If you ever \_\_\_\_\_ (find) yourself stuck in the middle of the



I \_\_\_\_\_ the world to find you .



If you ever \_\_\_\_\_ (find) yourself lost in the dark and you



I \_\_\_\_\_ (be) the \_\_\_\_\_ to guide you.



Find out what we're made of when we are called to help our friends in need.

You can count on me like one two three

I \_\_\_\_\_ (be) there

And I know when I \_\_\_\_\_ (need) it I can count on you like four three two

You \_\_\_\_\_ (be) there

'Cause that's what friends are supposed to do, oh yeah

Whoa, whoa Oh, oh Yeah, yeah

If you \_\_\_\_\_ and you \_\_\_\_\_ and you just



I \_\_\_\_\_ beside you



And if you ever \_\_\_\_\_ how much you really mean to me



\_\_\_\_\_ I \_\_\_\_\_ (remind) you





Ooh

Find out what we're made of when we are called to help our friends in need.

You can count on me like one two three

I \_\_\_\_\_ (be) there

And I know when I \_\_\_\_\_ (need) it I can count on you like four three two

You \_\_\_\_\_ (be) there

'Cause that's what friends are supposed to do, oh yeah

Oh, oh Yeah, yeah

You \_\_\_\_\_ always \_\_\_\_\_ (have) my



\_\_\_\_\_ when you

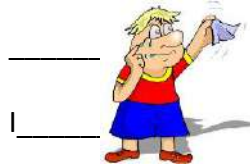

I \_\_\_\_\_ (let go)

Never \_\_\_\_\_

You know you can count on me like one two three

I \_\_\_\_\_ (be) there

And I know when I \_\_\_\_\_ (need) it I can count on you like four three two

And you \_\_\_\_\_ (be) there

'Cause that's what friends are supposed to do, oh yeah

Oh, oh

You can count on me 'cause I can count on you.

### III. Match the beginnings of the sentences to the correct endings.

#### IF- CLAUSE

(Condition – possible in the future)

#### MAIN CLAUSE

(Result)

If you ever find yourself stuck in the middle of the sea,  
 If you ever find yourself lost in the dark and you can't see,  
 If you are tossing and you're turning and you just can't fall asleep,  
 If you ever forget how much you really mean to me,

I'll sing a song beside you.  
 every day I will remind you.  
 I'll sail the world to find you.  
 I'll be the light to guide you.

We use the **First Conditional** to talk about situations that have a realistic chance of happening in the future.

## Anexo 3

**Monday**

**Week 1**

## BIM III

### I. Complete the sentences. Use the second conditional form of the verbs.

- If I \_\_\_\_\_ (win) the lottery, I'd be very happy.
- If I \_\_\_\_\_ (go) on holiday, I would go to the Bahamas.
- If I \_\_\_\_\_ (not live) here, I'd live in Florence.
- I \_\_\_\_\_ (not download) that programme if I were you.
- How you \_\_\_\_\_ (feel) if everybody \_\_\_\_\_ (forget) your birthday?

### II. Complete the text with the words in the list.

~~used~~ | up and down | wish | would had | laboratory

When I lived in London, I used to go to the zoo in Regent's Park every month, but now I work  
 in a \_\_\_\_\_ at the hospital and I don't have time. I \_\_\_\_\_ I wasn't so busy.  
 If I \_\_\_\_\_ more time, I \_\_\_\_\_ take my dog there so he could run  
 \_\_\_\_\_ the park.

### III. Circle the correct words.

- While Newton **was relaxing / relaxed** under a tree, an apple fell on his head.
- As Archimedes was getting out of the bath, he **was realising / realised** that the water went down.
- There was an explosion while Apollo 13 **was flying / flew** to the Moon.
- The students **were working / worked** in the lab when the lights went off.
- I **was searching / searched** the web when I found an interesting science site.

**I. Write questions. Use USED TO and the words.**

0. you / play any sports

Did you use to play any sports?

1. you / take the bus to school

\_\_\_\_\_ ?

2. Tom / have short hair

\_\_\_\_\_ ?

3. your grandparents / have a television when they were young

\_\_\_\_\_ ?

4. you / go to bed early when you were younger

\_\_\_\_\_ ?

**II. Choose the correct alternative.**

1. I ..... .. smoke, but now I have stopped.

a. used to                      b. use to                      c. am used to

2. That auditorium ..... .. be a cinema.

a. uses to                      b. used to                      c. am used to

3. I ..... .. like opera, but now I don't.

a. uses to                      b. used to                      c. am used to

4. I ..... .. like western music, but now I do.

a. use to                      b. used to                      c. am used to

5. I always ..... .. be afraid of the dark.

a. be use to                      b. is used to                      c. used to

**III. Write sentences using I wish.**

0 I have black hair. (blond) I wish I had blond hair.

1 I am shy. (not so shy) \_\_\_\_\_

2 I don't have enough free time. (more free time) \_\_\_\_\_

3 It rains all the time. (not rain) \_\_\_\_\_

4 I live in a village. (city) \_\_\_\_\_

5 I'm short. (taller) \_\_\_\_\_

## READING

*Last week, we asked you this question: What will life be like in 20 years' time? Here are some of your answers.*

### **ANNA**

There will be a lot more people in the world. It would be great if no one was hungry, and everyone had enough to eat. So, I think we will need to change our habits. We won't eat so much meat, because there won't be enough space for big animals. I think we'll eat insects instead of chickens or cows. But also, there won't be enough space for normal farms, so we will need to make tall towers and grow our vegetables inside them with special lights. It would be a very different type of farm from what we have today.

### **IVAN**

Computers will be even more intelligent soon. Think about it. What would you do if a computer was able to do your job better than you? Well, soon, that's going to be true. Computers will drive all cars, so goodbye truck and taxi drivers! Machines will replace receptionists, and there won't be people making our shirts and jackets anymore. We will just make what we need with 3-D printers. We will need to train people who can program computers and write code. People who aren't learning to do these things now might have big problems in the future.

### **BARBARA**

I read an article that the Internet will be everywhere. It's called "the Internet of things." Things will "talk" to other things. For example, your apartment will know when you are not there, and it will lock all the doors and switch off the lights for you. We will use smartphone apps to tell machines to water our plants outside when we are away. Your bathroom will know when you have no more toothpaste, and it will send a message to buy more. Your alarm clock will send messages to your coffee maker so you have hot coffee when you wake up. Your car will notify your house when you will arrive so that the house can adjust its temperature.

**I. Read the article. Match the topics (a–h) to the people in the article (1–3).**



- a) Food
- b) The home
- c) Clothes
- d) New buildings
- e) Gardens
- f) Shopping
- g) Education
- h) Work

**II. Read the article again. Mark these sentences T (true) or F (false), or DS (doesn't say).**

- 1. Anna thinks that people will eat different types of food in the future.
- 2. She says that we won't have farms.
- 3. Ivan thinks that most jobs will be the same in the future.
- 4. He knows how to program computers and write code.
- 5. He thinks we need to start learning now what we will need to do in the future.
- 6. Barbara says that we won't need technology much in the future.
- 7. She is worried about the future.

**WRITING**

I. Read the email invitation from a friend. Write a reply (100–125 words) saying that you would like to go, but can't. Use the ideas below to help you:

- You should do your homework before Friday morning.
- You would need to get permission from your parents.
- 9 p.m. is too late
- You are having your own party on Saturday at 7 p.m. at your house.

Hello,

We're organizing a party for Thursday night at my house. Would you like to come?  
It's from 9 p.m. to midnight, and everyone will be there.

Write soon,

Alex

---

---

---

---

---

---

---

---

**Friday**

I. Complete the sentences. Use the second conditional.

- o My parents work in a supermarket, so they are busy on Saturdays.  
If my parents didn't work in a supermarket, they wouldn't be busy on Saturdays.



- 1 I don't have a job, so I don't buy clothes.  
If I \_\_\_\_\_, I \_\_\_\_\_.
- 2 My car is very old, I spend a lot of money on it.  
I \_\_\_\_\_ if it \_\_\_\_\_.
- 3 My sister doesn't study and her results are bad.  
If my sister \_\_\_\_\_, her results \_\_\_\_\_.
- 4 The weather is awful, so we can't play outside.  
If the weather \_\_\_\_\_, we \_\_\_\_\_.
- 5 I don't have a phone so I can't text friends.  
If I \_\_\_\_\_, I \_\_\_\_\_.

**II. Complete the sentences with your ideas. Use the second conditional.**

- 0 If I were a famous scientist, I would fly to the moon.
- 1 If I had a private jet, \_\_\_\_\_
- 2 If I got lost in a big city, \_\_\_\_\_
- 3 The world would be a better place if \_\_\_\_\_
- 4 My schoolmates would be happier if \_\_\_\_\_
- 5 It would be fantastic if \_\_\_\_\_

**III. Write sentences with your own ideas. Use I wish.**

- 0 A scientist: I wish I could fly to the moon
- 1 A Maths teacher: I wish \_\_\_\_\_.
- 2 A person lost on a desert island: I wish \_\_\_\_\_.
- 3 An actor: I wish \_\_\_\_\_.
- 4 A contestant in a talent show: I wish \_\_\_\_\_.
- 5 An ill person: I wish \_\_\_\_\_.

**Anexo 4**

**Monday**

**BIM IV**

**Week 4**





**I. Complete the sentences. Use the correct Passive tense.**

1. A dangerous prisoner \_\_\_\_\_ (just catch) by the police.
2. My wallet \_\_\_\_\_ (find) on the bus yesterday – I'd left it there.
3. \_\_\_\_\_ your computer \_\_\_\_\_ (repair) right now?
4. The house \_\_\_\_\_ (not paint) for 20 years.
5. The offices \_\_\_\_\_ (clean) at 8.00 pm.

**II. Complete the sentences with *job* or *work*.**

1. A lot of young people are out of \_\_\_\_\_ in this country.
2. They have promised to create a lot of new \_\_\_\_\_.
3. I like my \_\_\_\_\_, it's hard but really interesting.
4. I'm glad you're happy with my \_\_\_\_\_ - I'm trying to do my best.

**III. Complete the sentences. Use the past simple, past perfect simple or past perfect continuous.**

0. Sara get dressed / go to work

After *she had got dressed*, Sara went to work.

1. Travis wait 2 hours / decide to go home

Tom \_\_\_\_\_.

2. Gianella think about it all night / knew what to do now.

Gianella \_\_\_\_\_.

3. the passengers / fly eight hours / reach New York.

After they \_\_\_\_\_.

4. John / drink a coffee / go back home.

After he \_\_\_\_\_.

5. all the players / warm-up / match start

Before the \_\_\_\_\_.

## Tuesday

**I. Match the part of the sentences**

- 0   a   I'll phone you
- 1        Max left home early, walked for a while,



- 2 \_\_\_\_ I'm going to learn how to swim
- 3 \_\_\_\_ I'll have a party
- 4 \_\_\_\_ You should tell your father
- 5 \_\_\_\_ The competition won't start

- a. ~~as soon as I get to the hotel.~~
- b. then he took the bus to school.
- c. until it stops raining.
- d. as soon as you can.
- e. when I get my first salary.
- f. while I'm at the seaside.

**II. Complete the questions. Use the present passive of the verbs.**

0 **Is coffee grown in Italy?**

- 1 \_\_\_\_\_ Mercedes cars \_\_\_\_\_ (produce) in France?
- 2 \_\_\_\_\_ Swahili \_\_\_\_\_ (speak) in Asia?
- 3 \_\_\_\_\_ surfboards \_\_\_\_\_ (make) of metal?
- 4 \_\_\_\_\_ your job \_\_\_\_\_ (pay) well?
- 5 \_\_\_\_\_ kangaroos \_\_\_\_\_ (find) in Europe?

**III. Complete the sentences. Use the past perfect of the verbs.**

0 **I'd been (be) at the bus stop for half an hour when the bus arrived**

- 1 Marvin stayed at home for two weeks after he \_\_\_\_\_ (have) the operation.
- 2 We thought we were late, but the film \_\_\_\_\_ (not start).
- 3 I thought I \_\_\_\_\_ (lose) my wallet, then I found it under the sofa.
- 4 Marta got very angry because Hugo \_\_\_\_\_ (not stop) at the red light.
- 5 When we got to the bank, it \_\_\_\_\_ (already / close).



# Wednesday

## READING

### I. Read the article. Match the information (1–8) with the numbers (a–h).

#### The best jobs

If you want to be healthy, one thing you need to do is choose a job that you love. After all, people spend a lot of their time working. But who are the happiest workers? Over 2,000 workers were interviewed, and here are the results. If you work with plants, you will be happy – 87% of people who work in gardens or with flowers love their careers. Florists – people who sell flowers – are at the top. Florists don't earn a lot of money, but they see beautiful things every day and meet a lot of people. Also, they can quickly see if they are successful. It's easy. If they have healthy flowers around them and happy customers, then they will know they have done a good job. This might be the most important thing of all and might explain why 79% of hairdressers also feel happy with their lives. They know if they've done a good job or not as soon as they have finished cutting someone's hair. However, only 62% of nurses, and 59% of teachers say that they are happy. Although they

work hard to make other people better, the results of this work are not seen so quickly. Or, they may never be seen. Another important thing is who you work for. Many florists or hairdressers are self-employed, meaning that they have their own company. Because of this, they don't have to worry about making their boss happy or being promoted. Research shows that over 90% of self-employed people are happy because they are able to control their own day, but only 54% of people who work for someone else are happy. Money doesn't always make you happy, of course. Research shows that people with a salary of more than \$78,000 a year are the unhappiest. Near the bottom of the list are IT workers. Despite their large salaries, only 48% love their jobs. Then, we have bankers – only 44% enjoy what they do. It seems that choosing a job because of what you might earn isn't always a good idea.

- |   |          |
|---|----------|
| 1. Happy teachers ( )                                 | a) 44%   |
| 2. Happy hairdressers (f)                             | b) 48%   |
| 3. Happy bankers ( )                                  | c) 54%   |
| 4. Happy florists ( )                                 | d) 59%   |
| 5. Happy IT workers ( )                               | e) 62%   |
| 6. The number of people who were questioned ( )       | f) 79%   |
| 7. Happy nurses ( )                                   | g) 87%   |
| 8. People who work for someone else and are happy ( ) | h) 2,000 |





## Friday

### I. Complete the sentences. Use the past perfect simple of the verbs in the list

speak | not recover | go | eat | turn | meet

- 0 After **she had spoken** to the doctors, Jane understood that her father's illness was nothing serious.
- 1 I remembered that I \_\_\_\_\_ him before at a school sports competition.
- 2 After they \_\_\_\_\_ for a run they had a drink.
- 3 \_\_\_\_\_ you already \_\_\_\_\_ before the guests arrived?
- 4 Kate had to stay in bed two more days because \_\_\_\_\_ from her cold.
- 5 We \_\_\_\_\_ just \_\_\_\_\_ the corner when we saw a group of people.

### II. Complete the text with either the past simple or the past perfect form of the verbs.

arrive | get | go | leave | eat | not go

When I **got** to the party, Tom 1. \_\_\_\_\_ already \_\_\_\_\_.  
But, he 2. \_\_\_\_\_ home – he'd been taken to hospital. He 3. \_\_\_\_\_ some fish before  
he 4. \_\_\_\_\_ at the party and felt very ill. I 5. \_\_\_\_\_ to the hospital to find him.

### III. Complete the sentences with your ideas. Use the past perfect continuous.

- 0 The football ground was wet in the morning because it **had been raining** all night.
- 1 The children's bedroom was in a terrible mess because they \_\_\_\_\_.
- 2 Tom was late because he \_\_\_\_\_.
- 3 The children were dirty because they \_\_\_\_\_.
- 4 We were hungry because we \_\_\_\_\_.
- 5 Alice felt sick because he \_\_\_\_\_.



**Inventario de actividades de Inglés (nivel: ADVANCED)  
(Apoyo a la recuperación académica 2017)**

Estimado estudiante:

Te proponemos el presente inventario de actividades como un recurso de apoyo para el proceso de recuperación académica que debes seguir durante el mes de enero de 2018. Te pedimos tener presente, respecto al inventario, lo siguiente:

- Ha sido elaborado de acuerdo con un temario anual, el cual considera los cuatro bimestres (25 % c/u).
- Las actividades que se presenta en él han sido tomadas de documentos de trabajo, libros del año escolar 2017 y de otras fuentes, pero que se ajustan a los contenidos del temario anual.
- Ha sido dosificado para ser desarrollado en cuatro semanas, de lunes a viernes, destinando para ello una hora diaria aproximadamente.
- El estudiante debe imprimir los documentos que serán desarrollados, archivados y presentados en un fólter manila tamaño oficio (incluir carátula), el mismo que será revisado y evaluado por los docentes responsables de la evaluación de recuperación, asignándole un peso de 25 % en el resultado final de la recuperación como "evaluación de portafolio". De hecho, si no lo presentases desarrollado, se te asignará la nota mínima en evaluación de portafolio.
- NOTA: Se adjunta hoja de respuestas para que al fin del trabajo pueda revisar su avance.
- Si los estudiantes requiriesen presentarse a la segunda oportunidad, podrán mejorar y volver a presentarlo desarrollado, prevaleciendo, en este caso, la segunda calificación. Si no lo hiciesen, mantendrán la calificación obtenida en la primera ocasión.
- En la tabla de control diario, el padre de familia debe firmar para apoyar y controlar el avance diario del estudiante en su desarrollo.
- No hemos incluido una calendarización específica para su desarrollo (fechas de inicio y fin), asumiendo que cada estudiante lo hará en coordinación con sus padres, considerando la realidad particular y los planes de la familia. En todo caso, el trabajo ha sido previsto para cuatro semanas.
- La primera oportunidad de evaluación será a fines de enero. La presentación del portafolio (inventario desarrollado) es obligatoria desde la primera oportunidad de evaluación.

WEEK	UNIT	TOPIC		
		N°	GRAMMAR	VOCABULARY
1	4 DILEMMAS	1	FIRST CONDITIONAL	BEING HONEST
		2	SECOND CONDITIONAL	MAKING A DECISION
2	6 HOW DO THEY DO IT?	1	PRESENT AND PAST PASSIVE	EXTREME ADJECTIVES
		2	FUTURE AND PRESENT PERFECT PASSIVE	MODIFIERS
3	8 IT'S A CRIME	1	REPORTED SPEECH	CRIME
		2	REPORTED QUESTIONS	REPORTING VERBS
4	10 MONEY	1	FUTURE CONTINUOUS	MONEY AND VALUE
		2	FUTURE PERFECT	JOBS AND WORK

<b>Tabla de firmas del padre de familia de control diario</b>					
	<b>Lunes 1 de enero</b>	<b>Martes 2 de enero</b>	<b>Miércoles 3 de enero</b>	<b>Jueves 4 de enero</b>	<b>Viernes 5 de enero</b>
<b>Semana 1</b>					
	<b>Lunes 8 de enero</b>	<b>Martes 9 de enero</b>	<b>Miércoles 10 de enero</b>	<b>Jueves 11 de enero</b>	<b>Viernes 12 de enero</b>
<b>Semana 2</b>					
	<b>Lunes 15 de enero</b>	<b>Martes 16 de enero</b>	<b>Miércoles 17 de enero</b>	<b>Jueves 18 de enero</b>	<b>Viernes 19 de enero</b>
<b>Semana 3</b>					
	<b>Lunes 22 de enero</b>	<b>Martes 23 de enero</b>	<b>Miércoles 24 de enero</b>	<b>Jueves 25 de enero</b>	<b>Viernes 26 de enero</b>
<b>Semana 4</b>					

**ANEXOS**





## Anexo 1

### WEEK 1

### MONDAY

**I. Read the text and circle the correct answer for each number.**

#### THE NETHERLANDS

Welcome to the Netherlands, a tiny country that only extends, at its broadest, 312 km north to south, and 264 km east to west - (0) **ALTHOUGH** the land area increases slightly each year as a (1) \_\_\_\_\_ of continuous land reclamation and drainage. With a lot of heart and much to offer, 'Holland,' as it is (2) \_\_\_\_\_ known to most of us abroad - a name stemming (3) \_\_\_\_\_ its once most prominent provinces - has more going on per kilometer than most countries, and more English-speaking natives. You'll be impressed by its (4) \_\_\_\_\_ cities and charmed by its countryside and villages, full of contrasts. From the exciting variety (5) \_\_\_\_\_ offer, you could choose a romantic canal boat tour in Amsterdam, a Royal Tour by coach in The Hague, or a hydrofoil tour around the biggest harbour in the world - Rotterdam. In season you could visit the dazzling bulb fields, enjoy a full day on a boat, or take a bike tour through the pancake-flat countryside spiced with windmills. The possibilities are countless and the nationwide tourist office, which is on hand to give you information and (6) \_\_\_\_\_ reservations. You'll have (7) \_\_\_\_\_ language problems here, as the Dutch are true linguists and English is spoken here almost universally.

- |                             |                 |                 |                    |
|-----------------------------|-----------------|-----------------|--------------------|
| 0. A) so                    | B) despite      | C) in spite of  | <b>D) although</b> |
| 1. A) whole                 | B) consequently | C) rule         | D) result          |
| 2. A) regularly             | B) occasionally | C) commonly     | D) unusually       |
| 3. A) in                    | B) from         | C) on           | D) of              |
| 4. A) historic<br>historian | B) historical   | C) historically | D)                 |
| 5. A) at<br>D) for          | B) in           | C) on           |                    |
| 6. A) sit                   | B) catch        | C) do           | D) make            |

7. A) few

B) a few

C) little

D) a

little

II. Read the text below and think of the word which fits each gap. Use only one word in each gap.

**THE HISTORY OF PAPER**

The history of paper is also the history of human culture and (0) **CIVILISATION**. The Egyptians, Greeks and Romans wrote on "papyrus", a paper-like material. Today's kind of paper was first (1) \_\_\_\_\_ and used in China. Paper was the most important carrier of information in the past. It was only with increasing paper production that the transfer of (2) \_\_\_\_\_, education and information to a larger portion of (3) \_\_\_\_\_ became possible.

With paper emperors were able to administrate large empires more easily. In former times paper was a (4) \_\_\_\_\_ product, and paper making an art - an art that was often kept secret because of the outstanding (5) \_\_\_\_\_ of the product. Today paper has changed from a rare artisan material to a commodity product, with a high (6) \_\_\_\_\_ value in communication, in educational, artistic, hygienic, sanitary, and technical applications. Nobody can imagine a word without paper. A large (7) \_\_\_\_\_ of paper grades are produced to suit the special (8) \_\_\_\_\_ of each application.

CIVILISE

CARRY

KNOW

SOCIAL

VALUE

ADVANCE

PRACTISE

VARY

REQUIRE

III. Circle the correct words.

0. Have you ever *said* / *told* a lie?

1. You should *do* / *be* the right thing and tell the truth.

2. Simon *opened* / *owned* up to breaking the window.

3. There's no point trying to *cheat* / *hide* the truth.

4. Did you think you would *get* / *be* away with stealing that money?

5. I have never *hidden* / *cheated* in a test in my life.

## TUESDAY

### IV. Complete the conversation with the words in the list.

reconsidering | bad | thought | right | made | come

**MARTA:** I still don't know what to study at university.

**SAM:** I thought you'd already (0) **made** up your mind about that? You (1) \_\_\_\_\_ long and hard and decided you wanted to study History.

**MARTA:** I know, but I'm (2) \_\_\_\_\_ that now.

**SAM:** You don't think it's the (3) \_\_\_\_\_ decision?

**MARTA:** No, I think it was a (4) \_\_\_\_\_ decision. I don't really enjoy History.

**SAM:** Well, you'd better (5) \_\_\_\_\_ to a decision before the end of the year!

### V. Circle the correct words to complete the dialogue.

**MARK:** Sara, if you (0) **see / will** Tim will you tell him I'll meet him at the sports centre at 6 o'clock?

**SARA:** Sure, I (1) **tell / 'll tell** him if I see him. But why don't you just text him?

**MARK:** I (2) **'d text / 'll text** him if he had a mobile phone, but he hasn't.

**SARA:** Has he lost another one? His mum said she (3) **won't / wouldn't** buy him any more if he did that again.

**MARK:** I know. I don't think he's going to tell her. She'll be really angry if he (4) **does / did!**

**SARA:** If I lost as many phones as Tim, I (5) **won't want / wouldn't** want another one! They're too expensive!

### VI. Choose the correct response for each of the sentences.

0. If his nose were smaller, he \_\_\_\_\_ very handsome.

- a) would be  
was

1. I would come if I \_\_\_\_\_ a car.

- a) would have  
b) had

2. If she \_\_\_\_\_, she would tell him.

- a) knows  
b) knew

3. If his parents didn't give him money, he \_\_\_\_\_ so much.

- a) wouldn't go out  
b) didn't go out

4. If she \_\_\_\_\_ me, she would have told me.

- a) didn't believe  
b) wouldn't believe

5. He wouldn't say that if he \_\_\_\_\_ it.  
 a) wouldn't mean  
 b) didn't mean
6. I \_\_\_\_\_ on a trip around the world if I won the lottery.  
 a) would go  
 b) will go
7. I \_\_\_\_\_ that if I were you.  
 a) will not do  
 b) would not do
8. If these walls \_\_\_\_\_ thicker, we wouldn't hear the neighbors.  
 a) would be  
 b) were
9. If I were a millionaire, \_\_\_\_\_ a mansion.  
 a) I'd buy  
 b) I'm going to buy

**VII. Complete the second sentence so that it has a similar meaning to the first sentence, using the word given. Do not change the word given. You must use between two and five words, including the word given.**

<p>0. Susan and Frank don't like each other.  <b>WELL</b></p> <p>Susan and Frank don't <b>GET ON WELL</b> with each other.</p>
<p>1. Was it necessary for her to spend so much money on it?  <b>HAVE</b></p> <p>Did _____ spend so much money on it?</p>
<p>2. It's possible that he hasn't been informed about his uncle's death.  <b>MIGHT</b></p> <p>He _____ informed about his uncle's death</p>
<p>3. Why did you sell such a great car?  <b>MADE</b></p> <p>What _____ such a great car?</p>
<p>4. 'What do you think of the new health centre?'  <b>ASKED</b></p> <p>She _____ of the new health centre.</p>

## WEDNESDAY

### VIII. Complete the sentences with the correct form of the words in the list.

come | forget | visit | ask | bake | not give

0. If you **had forgotten** to take your umbrella, you'd have got very wet!
1. I'd have had a great weekend if the teacher \_\_\_\_\_ us so much homework.
2. If I'd known, you were coming I \_\_\_\_\_ a cake.
3. You would have enjoyed yourself if you \_\_\_\_\_ with us to the concert.
4. If we'd had more time, we \_\_\_\_\_ more tourist sights.
5. Sam would have lent you the money if you \_\_\_\_\_ him.

### IX. For questions 1-7, read the text below and think of the word which fits each gap. Use only one word in each gap.

#### CATS

Cats of all kinds are present in the legends, religion, mythology, and history of (0) **MANY** different cultures. Cave paintings created by early humans display different types of wild cats (1) \_\_\_\_\_ are now extinct, or no longer around. Many of these great beasts saw humans as food, but were hunted by humans in return. Cats similar (2) \_\_\_\_\_ the ones kept as pets today started showing up in artwork thousands of years ago. For example, the ancient Egyptians believed cats were the sacred, or special, animal of a goddess named Bast. They believed that Bast often appeared as a cat, so many ancient Egyptians respected and honoured cats and kittens. (3) \_\_\_\_\_, other cultures feared cats or thought that they brought illnesses and bad luck. Today, with millions kept as pets in homes around the world, cats have become important members of many families. No one knows for sure when or (4) \_\_\_\_\_ cats became very popular household pets. It's possible that people noticed how cats hunted mice and rats, (5) \_\_\_\_\_ they set food and milk out to keep the cats near their homes. This helped to prevent (6) \_\_\_\_\_ many of these rodents (7) \_\_\_\_\_ coming into homes and eating people's food or spreading sickness.

### X. Circle the correct words.

0. If the baby wants more milk, she **'ll / 'd cry** for it.
1. If I was a teacher, I **won't / wouldn't** give homework.
2. What will you do if the bank **is / was** closed?
3. What would you do if someone **steals / stole** your phone?

4. I **'ll / 'd** get you a drink if you're thirsty.
5. If she **needs / needed** your help, she'd email you

**XI. Complete the sentences with the correct form of the verbs.**

0. If I **WERE** (be) you, I **WOULD GET** (get) a new job.
1. If he \_\_\_\_\_ (be) younger, he \_\_\_\_\_ (travel) more.
2. If we \_\_\_\_\_ (not/be) friends, I \_\_\_\_\_ (be) angry with you.
3. If I \_\_\_\_\_ (have) enough money, I \_\_\_\_\_ (buy) a big house.
4. If she \_\_\_\_\_ (not/be) always so late, she \_\_\_\_\_ (be) promoted.
5. If we \_\_\_\_\_ (win) the lottery, we \_\_\_\_\_ (travel) the world.
6. If you \_\_\_\_\_ (have) a better job, we \_\_\_\_\_ (be) able to buy a new.
7. If I \_\_\_\_\_ (speak) perfect English, I \_\_\_\_\_ (have) a good job.
8. If we \_\_\_\_\_ (live) in Mexico, I \_\_\_\_\_ (speak) Spanish.
9. If she \_\_\_\_\_ (pass) the exam, she \_\_\_\_\_ (be) able to enter university.
10. She \_\_\_\_\_ (be) happier if she \_\_\_\_\_ (have) more friends.
11. We \_\_\_\_\_ (buy) a house if we \_\_\_\_\_ (decide) to stay here.
12. They \_\_\_\_\_ (have) more money if they \_\_\_\_\_ (not/buy) so many clothes.
13. We \_\_\_\_\_ (come) to dinner if we \_\_\_\_\_ (have) time.
14. She \_\_\_\_\_ (call) him if she \_\_\_\_\_ (have) his number.
15. They \_\_\_\_\_ (go) to Spain on holiday if they \_\_\_\_\_ (like) hot weather.

**XII. Match the parts of the sentences.**

- |                                |              |
|--------------------------------|--------------|
| 0. I'll text you               | <u>  C  </u> |
| 1. Please don't start eating   | _____        |
| 2. What are you going to do    | _____        |
| 3. Don't give her your notes   | _____        |
| 4. He'll be angry              | _____        |
| 5. They are allowed to go home | _____        |

- A. when you get home tonight?
- B. if he doesn't win this race.
- C. as soon as I get there.
- D. unless she asks for them.
- E. as soon as they've finished this exercise.
- F. until I get home.

## THURSDAY

### XIII. Complete the sentences. Use your own ideas.

0. If I had been born in China, I'd be able to speak Chinese .
1. I'd have been very angry if \_\_\_\_\_ .
2. If it had snowed yesterday, \_\_\_\_\_ .
3. I'd have laughed a lot if \_\_\_\_\_ .
4. My teacher would have been happy if \_\_\_\_\_ .
5. If I had gone to bed at 1 a.m. last night, \_\_\_\_\_ .

### XIV. Complete the sentences with the correct forms of the verbs.

**study | have | would | can | live | not be**

0. It's freezing today. If only I had a warm coat.
1. I wish my brother \_\_\_\_\_ stop taking my stuff.
2. If only we \_\_\_\_\_ in a bigger apartment.
3. I wish I \_\_\_\_\_ visiting my aunt.
4. If only I \_\_\_\_\_ harder for the exam.
5. I wish I \_\_\_\_\_ go on holiday.

### XV. Read the text and circle the correct answer for each number.

#### THE STORY OF GOLD

The story of gold is an adventure involving kings, queens, pirates, explorers, conquerors, and the native peoples they conquered. Throughout history, gold has woven a magic spell over those it touched. Gold is beautiful and rare; a soft shiny metal that can be moulded into many (0) SHAPES. It has been used for money, jewellery, and to decorate special buildings such (1) \_\_\_\_\_ palaces and places of worship. (2) \_\_\_\_\_ the precious metal was discovered, prospectors rushed to mine it, starting new cities and countries as they went. Gold and the people who love it have helped shape the world we live (3) \_\_\_\_\_ today. Gold is one of many elements, or substances that cannot be changed by normal chemical means, that are found in the Earth's crust. Gold has a warm, sunny colour and (5) \_\_\_\_\_ it does not react (5) \_\_\_\_\_ air, water, and most chemicals, its shine never fades. In its natural (6) \_\_\_\_\_ gold is soft and easily shaped. When heated to 1,062 Celsius it melts and can be poured into molds to form coins, gold bars, and other objects. Stories have been told, movies



(7) \_\_\_\_\_ and legends born about the discovery of the world's great gold deposits. It is a saga of dreams, greed, ambition and exploration.

- |    |            |             |             |             |
|----|------------|-------------|-------------|-------------|
| 0. | A) formats | B) outlines | C) shapes   | D) lines    |
| 1. | A) as      | B) like     | C) many     | D) to       |
| 2. | A) Whoever | B) However  | C) Forever  | D) Wherever |
| 3. | A) at      | B) in       | C) for      | D) on       |
| 4. | A) yet     | B) despite  | C) because  | D) so       |
| 5. | A) with    | B) in       | C) of       | D) at       |
| 6. | A) estate  | B) stage    | C) state    | D) position |
| 7. | A) done    | B) made     | C) composed | D) built    |

## FRIDAY

XVI. Read the story. Then answer the questions below.



### “The Mini Problem”

Lily's anger could not have been more **palpable**.

She awakened Christmas morning and, along with her brother, ran down to see the gifts under the tree.

In the living room sat a magnificent mini bike. It was red with a pearly white gas tank and side panels. For a brief moment, Lily was filled with what seemed like **insurmountable** excitement. She couldn't imagine anything better than getting that bike. Then, her eyes caught sight of a baby doll sitting on the couch with a huge bow.

She knew. She knew that the mini bike belonged to her brother and that she had been **relegated** to that doll. It was par for the course.

Tommy always got cool things: skateboards, gliders, science kits. The mini bike was just the latest cool thing.

Lily always got the boring gifts: a doll with a gown, a doll with a tutu, a doll with a puppy. This doll seemed unusually blah. The doll wore a petticoat. The doll had short, straight black hair.

Tommy had seen that mini-bike in the front window of Moore's Bike Shop, but hadn't Lily too? Both had begged for the bike. Both had said it was the only thing they wanted for Christmas. Hadn't Lily asked for it with as much **fervor** as her twin brother?

Tommy's eyes grew wide at the sight of the bike he knew was his—no doll for him. He ran into his parents' room and jumped excitedly on the bed.

“Thank you, Mama! Thank you, Papa!” he yelled.

Meanwhile Lily simmered in the other room. She was furious. She was enraged. She was **incensed**. It took a while for anyone to even realize she was missing.

“What’s wrong, Lil?” Papa asked. “Did you see your pretty doll?” “I saw it,” she said sulkily.

“What’s wrong?” asked Mama.

Silence. Lily’s jaw was fixed. Her hands clenched. Her whole body trembled.

“Oh, Mama, you know Lily is never excited by presents!” her brother laughed. “Come out and watch me ride!”

And so they did.

**1) In the beginning of the story, Lily's anger was described as palpable because it was:**

- A. unusual
- B. irrational
- C. difficult to understand
- D. easy to feel

**2) As used in the beginning of the story, which is the best antonym for insurmountable?**

- A. sane
- B. phony
- C. unjustified
- D. surpassable

**3) As used in the beginning of the story, which best describes the act of being relegated?**

- A. A star athlete is given a coveted award.
- B. A disobedient dog is put in the garage to sleep.
- C. After being tested; swimmers are put into groups according to their ability levels.
- D. The birthday boy is taken to his favorite restaurant.

**4) As used in the beginning of the story, the expression par for the course implies that something**

- A. is to be expected
- B. cannot be undone
- C. is sure to cause anger
- D. was meant to be hurtful

**5) What is ironic about the title of this passage?**

- A. Lily has a big problem.
- B. Tommy is perfectly happy.
- C. Lily does not get a mini bike.
- D. Lily’s parents do not realize there is actually a problem.

**6) What could the author have written if she wanted to show Lily taking steps to improve her situation?**

- A. a scene with Lily storming out of the house
- B. a description of Lily getting to ride the mini bike first
- C. a paragraph describing Lily pretending to appreciate the doll
- D. a dialogue with Lily explaining to her family why she was so angry

**7) As used in the middle of the story, which is the best antonym for fervor?**

- A. gluttony
- B. indifference
- C. politeness

D. passion

8) In paragraph 6, the author most likely repeats the word "doll" to

- A. highlight how extravagant the dolls were
- B. juxtapose the number of dolls with just one mini bike
- C. emphasize how common this gift had become for Lily
- D. make it clear that the doll she got this Christmas was the worst of all

9) As used at the end of the story, which is the best antonym for incensed?

- A. pleased
- B. annoyed
- C. patient
- D. indignant

**MONDAY**

**WEEK 2**

I. Read the text below and think of the word which fits each gap. Use only one word in each gap.

**ABOUT FISH AND AQUARIUMS**

There are more than 200,000 species of fish inhabiting many (0) **DIFFERENT** waters. New species of fish are discovered every year. From the deepest part of the seas thousands of feet down in total (1) \_\_\_\_\_, to the beautiful aqua-blue waters of the coral reefs, to the streams, lakes, and ponds of freshwater found throughout the world, fish have adapted an incredible variety of life-forms, styles, and (2) \_\_\_\_\_. The group of aquatic animals we call fishes has evolved for over 400 million years to be the most (3) \_\_\_\_\_ and diverse of the major vertebrate groups. Forty-one percent of the world's fish species inhabit only fresh water. This is pretty (4) \_\_\_\_\_ considering that fresh water covers only 1 percent of the world's surface. As you probably already know salt water covers 70 percent of the earth's surface. So the number and (5) \_\_\_\_\_ of fresh water species to marine or saltwater species is all the more mind-boggling. While they inhabit the smallest amount of water, they have, in fact, adapted to a much (6) \_\_\_\_\_ range of habitats and to a greater variety of water conditions. Let's take a closer look at the unique adaptations of fish that have allowed them to live so (7) \_\_\_\_\_ in the medium we call water.

DIFFER

DARK

BEHAVE

NUMBER

AMAZE

VARY

WIDE

SUCCESS

II. Put the adjectives

fantastic  
delighted  
big |

EXTREME	GRADABLE
_____	_____
_____	_____
_____	_____
_____	_____

into the correct column.

| tiny | small |  
| funny | happy |  
hilarious

III. Complete the text with the words in the list.

nice | happy | huge | fantastic | tiny | amazing

I've just returned from a week-long trip to the USA – it was absolutely (0) **fantastic**. We hired a very (1) \_\_\_\_\_ car from the airport in New York and we drove about 100 miles every day. Of course, the USA is an absolutely (2) \_\_\_\_\_ country, so we only saw a (3) \_\_\_\_\_ part of it – but what we did see was absolutely (4) \_\_\_\_\_. I'm really (5) \_\_\_\_\_ we went!



PASSIVE VOICE

## TUESDAY

### IV. Complete the sentences. Use the correct form of the present passive.

1. This TV programme **is shown** (show) every Saturday evening.

TENSE	ACTIVE	PASSIVE
Present Simple	They <b>speak</b> German in Austria.	German <b>is spoken</b> in Austria.
Present Continuous	They <b>are planting</b> some trees.	Some trees <b>are being planted</b> .
Present Perfect	Someone <b>has eaten</b> my muffin.	My muffin <b>has been eaten</b> .
Past Simple	They <b>closed</b> the road for a day.	The road <b>was closed</b> for a day.
Past Continuous	He <b>was not feeding</b> his dogs.	His dogs <b>were not being fed</b> .
Past Perfect	Someone <b>had put out</b> the fire before the fire brigade arrived.	The fire <b>had been put out</b> before the fire brigade arrived.
Future Simple	They <b>will fine</b> you for littering.	You <b>will be fined</b> for littering.
Future with 'be going to'	They <b>are going to raise</b> taxes.	Taxes <b>are going to be raised</b> .
Modal verbs	You <b>can solve</b> the problem.	The problem <b>can be solved</b> .

2. Students at my school \_\_\_\_\_ (not teach) how to play musical instruments.
3. The front door \_\_\_\_\_ (lock) every night at 11 o'clock.
4. Our old car \_\_\_\_\_ (not use) very much anymore.
5. My best photographs \_\_\_\_\_ (display) on the wall in the hallway.

6. The windows \_\_\_\_\_ (clean) twice a month.

**V. Complete the sentences. Use the correct form of the passive.**

- 0. Maria was **TOLD** to stop singing. (tell)
- 1. They were \_\_\_\_\_ by the ending. (surprise)
- 2. Michael was \_\_\_\_\_ by his grandparents. (raise)
- 3. This house was \_\_\_\_\_ by a famous architect. (design)
- 4. The child was \_\_\_\_\_ up by his father. (pick up)
- 5. The bank robbers were never \_\_\_\_\_. (catch)
- 6. This book was \_\_\_\_\_ by Ernest Hemingway. (write)
- 7. This stadium was \_\_\_\_\_ for the Olympic Games. (build)
- 8. My flight was \_\_\_\_\_ because of bad weather. (delay)
- 9. Classes were \_\_\_\_\_ by the principal. (cancel)

**VI. Change these active sentences to passive.**

- 0. My grandfather built this house in 1943.  
**This house was built in 1943 by my grandfather.**
- 1. People speak Portuguese in Brazil.  
\_\_\_\_\_
- 2. I had cleaned all the windows before the storm.  
\_\_\_\_\_
- 3. He had written three books before 1867.  
\_\_\_\_\_
- 4. They are building a new stadium near the station.  
\_\_\_\_\_
- 5. The cleaner has cleaned the office.  
\_\_\_\_\_

**VII. Complete the second sentence so that it has a similar meaning to the first sentence, using the word given. Do not change the word given. You must use between two and five words, including the word given.**

0. It wasn't Mark that you met in the shop. <b>HAVE</b>  It <b><u>COULDN'T HAVE BEEN</u></b> Mark that you met in the shop.
1. She was just going to have her breakfast when the phone rang. <b>ABOUT</b>

<p>She was just _____ breakfast when the phone rang.</p>
<p>2. Steve didn't manage to complete his work. <b>FAILED</b></p> <p>Steve _____ his work.</p>
<p>3. How long has she been studying English? <b>BEGIN</b></p> <p>When _____ studying English?</p>
<p>4. George wrote his last novel five years ago. <b>WAS</b></p> <p>It _____ George wrote his last novel.</p>
<p>5. Nobody took any notice of his bad behaviour. <b>ATTENTION</b></p> <p>Nobody _____ his bad behaviour.</p>

## WEDNESDAY

### VIII. Complete the sentences with the correct form of make or do.

0. Try not to **make** too much noise when you come home tonight.
1. I'll come out after I've \_\_\_\_\_ the housework.
2. The reason you don't understand it is because it doesn't \_\_\_\_\_ sense.
3. He needs to find a way to \_\_\_\_\_ money fast.
4. Marco \_\_\_\_\_ really well in his exams last year.
5. Will passengers please \_\_\_\_\_ their way to the departure lounge?

### IX. Put the words in order to make sentences.

0. every / We / our windows / have / cleaned / month  
**We have our windows cleaned every month.**
1. checked / got / by / my Dad / my homework / I

\_\_\_\_\_

2. going to / her / She's / cut / tomorrow / hair / have

\_\_\_\_\_

3. you / a tattoo / ever / Have / had / done ?

\_\_\_\_\_

4. We / our house / had / painted / last summer

\_\_\_\_\_

5. did / your bike / Where / get / you / fixed ?

X. For questions 1-7, read the text below and think of the word which fits each gap. Use only one word in each gap.

### GUTENBERG

Before Gutenberg (1394 – 1468), all books had to be copied by hand. The so-called 'manuscripts' of medieval times were laboriously hand-written, usually by monks (0) WHO devoted years (1) \_\_\_\_\_ the work. Earlier attempts had been made to produce printing 'blocks'. The designs on playing cards (2) \_\_\_\_\_ example were carved from wooden blocks which were inked and then printed onto cards. There are even examples of whole pages in books being hand carved and printed. Gutenberg however came up with the idea of printing using, not whole page blocks, but letter blocks. (3) \_\_\_\_\_ he was a goldsmith (4) \_\_\_\_\_ trade, he knew how to mould metal into whatever shape was needed. He made thousands of tiny blocks of 'type', (5) \_\_\_\_\_ with a letter raised on it, which could be lined up and clamped into position in a 'forme' (page block). The type could be linked, paper laid on top, and the whole thing compressed by turning a handle. When released, the paper had the page printed on it. Years of work went into this invention. Gutenberg (6) \_\_\_\_\_ to make the letters, develop an ink which would cling to metal (most didn't), build the forme, and above (7) \_\_\_\_\_ find the money to do all this while not working as a goldsmith.

**THURSDAY**

XI. Underlined the correct words.



0. The burglars **are / were** arrested last night.
1. I **am / is** given \$10 pocket money every week.
2. **Was / Were** they beaten by many points?
3. Our chickens **aren't / isn't** kept in cages.
4. The experiment **was / were** done in the laboratory.
5. Lots of English words **is / are** spelled strangely.

**XII. Complete the sentences with the future or present perfect passive form of the words in brackets.**

0. This bicycle **hasn't been cleaned** (not clean) since last year.
1. Students \_\_\_\_\_ (not allow) to use calculators in the next test.
2. Lots of food \_\_\_\_\_ (prepare) for tonight's party already.
3. The children \_\_\_\_\_ (not give) their lunch money yet.
4. The final match \_\_\_\_\_ (play) next Saturday at 10 am.
5. A lot of questions still \_\_\_\_\_ (not answer).

**XIII. Rewrite the sentences in the passive. Use by + agent if necessary.**

0. The Queen opened the museum.  
**The museum was opened by the Queen.**
1. They built this library in 1964.  
\_\_\_\_\_
2. They won't let you in if you're late.  
\_\_\_\_\_
3. My cat wakes me up every morning.  
\_\_\_\_\_
4. Nobody has fed the dog today.  
\_\_\_\_\_
5. My dad drove me to school this morning  
\_\_\_\_\_

**XIV. Read the text and circle the correct answer for each number.**

**TOURISM**

Tourism is one of the world's largest industries, and it is the fastest growing. It contributes over £50 billion to the economy annually, over £12 billion of it from overseas visitors. About 25 million overseas visitors (0) **COME TO** Britain each year. Tourism is one of the biggest employment (1)

\_\_\_\_\_ in the UK, too – it employs over 1.7 million people, which is more than in the construction or health service industries.

Around 20% of all new (2) \_\_\_\_\_ are in this industry. These figures are very impressive, but how do they translate (3) \_\_\_\_\_ job possibilities for you? There is room in this industry for all sorts of people, with different educational (4) \_\_\_\_\_ personal attributes, interests and career aims. A tourist is really a traveller – someone who (5) \_\_\_\_\_ a journey, usually for recreation, (6) \_\_\_\_\_ a holiday or sightseeing. (7) \_\_\_\_\_, tourism at its very simplest refers to the industry that provides travel and entertainment facilities for people away from their own homes.

0. A) come from    **B) come to**    C) come away with    D) come down to
1. A) zones    B) sections    C) districts    D) sectors
2. A) works    B) jobs    C) employments    D) vocations
3. A) into    B) from    C) for    D) at
4. A) in    B) on    C) for    D) at
5. A) surroundings    B) traditions    C) backgrounds    D) settings
6. A) makes    B) does    C) performs    D) breaks
7. A) as    B) such    C) so    D) like
8. A) although    B) despite    C) therefore    D) because

## FRIDAY

XV. Read the story. Then answer the questions below.

### “City Girl”

I am a city girl at heart. I’ve never milked a cow – never wanted to. I was shocked when I attended my first “pig pickin’” after my husband and I moved to North Carolina from Boston. I had to **avert** my eyes from the huge pig, skin and head still on, splayed open across an oil drum that had been sawed in half lengthwise and fitted with hinges so it opened and closed.

This, I later learned, was called a “pig cooker.” Part of the pig’s insides were chopped up in a pan beside it and referred to as “barbecue.” Seeing all of this did not improve my appetite.

“Y’all in thuh country now, gul,” the host told me happily, apparently thrilled to be the one to indoctrinate me into country living.

When, at 8 months pregnant, I volunteered to chaperone my son’s strawberry-picking field trip, the other mothers looked at me strangely. I thought strawberries grew on tall bushes, not low to the ground. All that squatting sent me into early labor.



You should keep these incidents in mind in order to understand my attitude when I heard a “huge hurricane” was headed toward our town. I thought back to the snowstorms forecast during my days growing up in Philadelphia. The “20 inches” predicted by the weatherman never seemed to **materialize**.

The local newspaper ran a long checklist of things townspeople should get to prepare for the hurricane. My neighbor, Wayne, aware that I was new to town, made a point of giving me a copy of the list. I took a  **cursory** glance and thought nothing more of it.

While my neighbors were running around taping their windows, buying fresh batteries, and prepping their generators, I was, quite **literally**, sitting in my glass house playing with the kids on the floor.

The rains started at 2 o’clock in the afternoon. To my amazement, this was exactly what the weatherman had predicted.

These were no ordinary rains, either. From my glass living room, I could no longer see the front lawn or the trees. The rain was as thick as a woolen curtain. By nightfall, my husband’s car had begun to float out of the driveway. The water started insidiously creeping up our front steps, overturning potted plants and benches in its wake.

“This is unbelievable!” I yelled. I reached for the phone to dial Wayne. He had been born and raised in these parts; surely he would know what to do.

“Wayne,” I said worriedly into the receiver. “The water is coming up our front steps. It’s almost to our door!”

“Ours, too,” he said, quite calmly, I thought, given the circumstances. “What should I do?”

“Put out your sandbags. It will keep the water out as long as it doesn’t get too high.”

“Sandbags?”

“You didn’t get any?” he asked in disbelief. “They were on the list.” No, I hadn’t.

**1) What other title might fit this passage best?**

- A. "An Urban Attitude"
- B. "Learning Hurricanes"
- C. "Picking Strawberries"
- D. "Snow Storms that Don't Come"

**2) What seems to be the author's main purpose in the first four paragraphs of this passage?**

- A. to let the reader know that the narrator went into early labor
- B. to let the reader know that the narrator does not like barbecue
- C. to let the reader know that the narrator is unfamiliar with country life
- D. to let the reader know that the narrator wants to move back to Boston

**3) “I had to avert my eyes from the huge pig, skin and head still on, splayed open across half of an oil drum that had been sawed in half lengthwise.”**

**Which of the following is the best way to rewrite the above sentence (from paragraph 2) while keeping its original meaning as used in the story?**

- A. I had to open my eyes to the huge pig, skin and head on, splayed open across an oil drum that had been sawed in half lengthwise.”
- B. I had to direct my eyes towards the huge pig, skin and head on, splayed open across an oil drum that had been sawed in half lengthwise.
- C. I had to turn my eyes away from the huge pig, skin and head on, splayed open across an oil drum that had been sawed in half lengthwise.
- D. I had to fix my eyes upon the huge pig, skin and head on, splayed open across an oil drum that had been sawed in half lengthwise.

**4) As used in paragraph 5, which is the best definition for materialize?**

- A. to be false
- B. to increase in size
- C. to become actual or real
- D. to be concerned with consumer goods.

**5) Which literary term best applies to the following quote: “Y’all in thuh country now, gul.”**

- A. yarn, meaning an improbable tale
- B. trait, characterized as a habit or tendency in one’s personality
- C. caprice, characterized as expressing fanciful or odd notions
- D. vernacular, meaning the native language of people in a particular geographical area.

**6) Which best describes the narrator's attitude in this passage?**

- A. disdainful of rural life
- B. unaware of country ways
- C. anxious to get back to Boston
- D. wishful for her children to grow up in the city

**7) As used in the middle of the story, which is the best antonym for cursory?**

- A. angry and willful
- B. fast and intelligent
- C. slow and deliberate
- D. slow and superficial

**8) What does it mean to literally do something?**

- A. to think about doing something
- B. to do something exactly as said
- C. to do something and regret it later
- D. to do something with a bad attitude

**9) What message does the author convey by having the narrator wait out the storm in a glass room?**

- A. It signifies how vulnerable she is.
- B. It signifies the narrator's nontraditional tastes.

C. It lets the reader know that she has not taped up her windows.

D. It lets the reader know she can see everything that's going on.

**10) Which lesson does the narrator most likely learn during the hurricane?**

A. The early bird catches the worm.

B. Marry in haste and repent at leisure.

C. An ounce of prevention is worth a pound of cure.

D. Actions speak louder than words.



**MONDAY**

**I. Match the words with the definitions.**

- |               |                          |
|---------------|--------------------------|
| 0. robber     | <input type="checkbox"/> |
| 1. con man    | <input type="checkbox"/> |
| 2. mugger     | <input type="checkbox"/> |
| 3. pickpocket | <input type="checkbox"/> |
| 4. burglar    | <input type="checkbox"/> |
| 5. shoplifter | <input type="checkbox"/> |

- a) A person who steals from another, using violence or the threat of violence.
- b) A person who breaks into houses and steals things.
- c) A person who steals things.
- d) A person who tricks someone into giving them money.
- e) A person who steals from shops.
- f) A person who steals things from people's bags or pockets.

**II. Complete the sentences with the words in the list.**

**committed | arrested | broke | prison | trouble | fine**

- 0. The police arrested the burglar as he climbed out of the window.
- 1. I got a \_\_\_\_\_ of £25 for throwing litter in the park.
- 2. She has never \_\_\_\_\_ a crime in her life.
- 3. You will be sent to \_\_\_\_\_ if the police catch you.
- 4. I don't want to get into any \_\_\_\_\_.
- 5. The police think the burglar \_\_\_\_\_ in through the back door.

**III. Underlined the best verbs to report these statements.**

- 0. "OK, I'll meet you at 8 o'clock."

**agree / invite**

1. "You should go and see that film – it's great."

**demand / recommend**

2. "Would you like to come to the beach with us this afternoon?"

**persuade / invite**

3. "No, I won't tell you the answer."

**refuse / demand**

4. "This new system will reduce crime by 50%."

**encourage / claim**

5. "I insist that you clean your room right now."

**demand / persuade**

#### IV. Complete the sentences.

0. "We want to have CCTV in every street."

They said they wanted CCTV cameras in every street.

1. "I think muggers should go to prison."

He said he \_\_\_\_\_ muggers should go to prison.

2. "They didn't phone me."

She said they \_\_\_\_\_ her.

3. "I'll call the police."

He said he \_\_\_\_\_ the police.

4. "We can't arrest him without evidence."

They said they \_\_\_\_\_ him without evidence.

5. "You're going to get into trouble."

He said I \_\_\_\_\_ into trouble.

V. Read the text below and think of the word which fits each gap. Use only one word in each gap.

**LUXEMBURG**

The Grand Duchy of Luxembourg is a constitutional monarchy headed by Grand Duke Henri of the House of Nassau. Economically, the (0) **STRENGHT** of its banking and (1) \_\_\_\_\_ institutions has attracted more than 200 foreign banks, including the headquarters of the European Investment Bank. The 480,000 (2) \_\_\_\_\_ have among the highest income levels per capita of any country in the world. Agriculture is still (3) \_\_\_\_\_. Around half of the total land area is farmed, though less than 5% of Luxembourgers now live and work on farms. Despite problems caused by overproduction of European wines in general, the vineyards are still (4) \_\_\_\_\_. And the enchanting Luxembourg countryside, (5) \_\_\_\_\_ its northern reaches in the Ardennes, is a popular holiday destination for Luxembourgers and (6) \_\_\_\_\_ from neighbouring countries. Having played a key role in establishing the institutions that evolved into the European Union, Luxembourg today hosts the secretariat of the European Parliament. In such a small country, with bigger neighbours on its doorstep, Luxembourgers have a distinctive individuality that even extends to the (7) \_\_\_\_\_ language, Letzebuergesch, which is vaguely related to both French and German, yet quite different from both.

- STRONG  
FINANCE  
RESIDE  
IMPORT  
COMPET  
PARTICULAR  
VISIT  
NATION

**TUESDAY**

VI. Put the words in the correct order to make sentences.

0. asked / The policeman / where / had / I / me / been

**The policeman asked me where I had been.**

1. claimed / never / he / had / He / a crime / committed

\_\_\_\_\_

2. her / to go / Her teacher / to college / encouraged

\_\_\_\_\_

3. you / I / not to / told / too long / stay out

\_\_\_\_\_

4. us / They / if / worried / we / about / were / crime / asked

\_\_\_\_\_

5. agreed / it / We all / a fantastic / had been / holiday

---

**REPORTED SPEECH**

DIRECT SPEECH	INDIRECT SPEECH
<b>Simple Present</b> <i>"I never eat meat", he explained.</i>	<b>Simple Past</b> <i>= He explained (that) he never ate meat.</i>
<b>Present Continuous</b> <i>"I'm waiting for Ann", he said.</i>	<b>Past Continuous</b> <i>= He said (that) he was waiting for Ann.</i>
<b>Present Perfect</b> <i>"I have found a flat", he said.</i>	<b>Past Perfect</b> <i>= He said (that) he had found a flat.</i>
<b>Present Perfect Continuous</b> <i>He said, "I've been waiting for ages".</i>	<b>Past Perfect Continuous</b> <i>= He said (that) he had been waiting for ages.</i>
<b>Simple Past</b> <i>"I took it home with me", she said.</i>	<b>Past Perfect</b> <i>= She said (that) he had taken it home with her.</i>
<b>Future</b> <i>He said, "I will/shall be in Paris on Monday".</i>	<b>Conditional</b> <i>= He said (that) he would be in Paris on Monday.</i>
<b>Future Continuous</b> <i>"I will/shall be using the car myself on the 24h", she said.</i>	<b>Conditional Continuous</b> <i>= She said (that) she'd been using the car herself on the 24th.</i>
<b>Conditional</b> <i>I said, "I would like to see it".</i>	<b>Conditional</b> <i>= I said (that) I would like to see it.</i>

**VII. Complete the reported questions, requests and commands.**

- 0. "Put your hands up!"  
He told him to put his hands up.
- 1. "When are you going out?"  
He asked me \_\_\_\_\_.
- 2. "What time did you leave the office?"  
The policeman asked her \_\_\_\_\_.
- 3. "Have you heard about the burglary?"  
She asked him \_\_\_\_\_.
- 4. "Don't forget to lock all the doors!"  
We told them \_\_\_\_\_.
- 5. "What were you doing when you heard the explosion?"  
She asked me \_\_\_\_\_.

**VIII. Complete the conversations with the words in the lists.**

awful | believe | guess | Really | Tell | What

A: You'll never (0) guess what happened yesterday!

B: (1) \_\_\_\_\_ ?

A: You won't (2) \_\_\_\_\_ it.

B: (3) \_\_\_\_\_ me!



A: I got mugged on my way home from school!

B: (4) \_\_\_\_\_ ?

A: Yes! It was so scary.

B: That's (5) \_\_\_\_\_ !

**IX. For questions 1-7, read the text below and think of the word which fits each gap. Use only one word in each gap.**

### HOLIDAYS

Whatever you do in tourism, you are likely to have a (0) **A LOT OF** of contact (1) \_\_\_\_\_ other people. This can be both enjoyable (2) \_\_\_\_\_ difficult. You will soon find (3) \_\_\_\_\_ how often people behave unlike their usual selves while on holiday, or trying to arrange a holiday. (4) \_\_\_\_\_ they stay in their own country or go abroad, they want to get away from it all, they (5) \_\_\_\_\_ paying hard-earned money to relax from work, and they want value (6) \_\_\_\_\_ money.

They will also be in unfamiliar surroundings and unsure of themselves. When things go well their happiness is infectious - it is very rewarding helping (7) \_\_\_\_\_ and contributing to the enjoyment of their holiday. When things go badly, clients blame the hotel staff or tour operator's representative, even if it isn't their fault. You've just got to keep calm and keep smiling when people are shouting at you.

## WEDNESDAY

**X. Change the reported speech into mini-dialogues.**

0. Steve told Sue he liked her new hairstyle. She told him she'd cut it herself.

I like your new hairstyle.

STEVE

I cut it myself.

SUE

1. Mark asked Tom if he could lend him £5. Tom said he didn't have any money.

\_\_\_\_\_ ?

MARK

\_\_\_\_\_

TOM

2. Sonja told Simon not to damage her laptop. Simon said he'd try not to.

\_\_\_\_\_ ?

SONJA

\_\_\_\_\_

SIMON

3. James said he'd just seen a fantastic horror film. Jenny said she didn't like horror films.

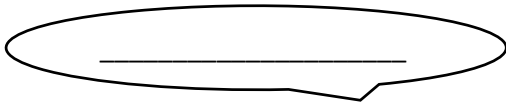

**JAMES**



**JENNY**

4. Sally asked Jim if he had ever committed a crime. Jim said he hadn't.



**SALLY**



**JIM**

5. Harry asked Tina if she could play a musical instrument. She told him she couldn't.

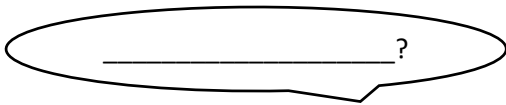

**HARRY**



**TINA**

**XI. Complete the sentences with the correct forms of the verbs in brackets.**

0. Who persuaded you **to have** (have) a barbecue this evening?
1. I hope you apologised for \_\_\_\_\_ (lose) Sam's pen.
2. My sports teacher encouraged me \_\_\_\_\_ (take up) climbing.
3. I didn't suggest \_\_\_\_\_ (leave) your bicycle here.
4. We agreed \_\_\_\_\_ (not tell) anyone about the crime we had committed.
5. Who recommended that you \_\_\_\_\_ (join) the police force?

**XII. Complete the sentences.**

0. "The police are investigating the incident."  
He said the police **were** investigating the incident.
1. "Will you open your window, please?"  
He asked me if I \_\_\_\_\_ my window.
2. "Have you found your lost handbag?"  
He asked her if she \_\_\_\_\_ her lost handbag.
3. "Get out of bed!"  
She told them \_\_\_\_\_ of bed.
4. "I can do the shopping for you."  
He offered \_\_\_\_\_ the shopping for me.
5. "I think I'm going to be sick."  
She said she \_\_\_\_\_ to be sick.

**XIII. Circle the correct letter.**

0. **A:** He said he'd help me find my dog.  
B: He said he'll help me find my dog.
1. A: She said she already ate.  
B: She said she'd already eaten.
2. A: I asked her if she was feeling ill.  
B: I asked her if was she feeling ill.
3. A: Sam encouraged his friend be naughty.  
B: Sam encouraged his friend to be naughty.
4. A: I told you to not do that!  
B: I told you not to do that!
5. A: He offered to cook dinner that evening.  
B: He offered cooking dinner that evening

**THURSDAY**

**XIV. Complete the sentences.**

0. "I've decided to become a police officer."  
She said **she had decided to become a police officer.**
1. "You really should go training more often."  
He encouraged me \_\_\_\_\_.
2. "No, I won't tell a lie."  
She refused \_\_\_\_\_.
3. "Alright, I'll write Jake's essay."  
He agreed \_\_\_\_\_.
4. "Don't drink the water!"  
He told us \_\_\_\_\_.
5. "I've never met a murderer."  
She said \_\_\_\_\_.

**XV. Change the sentences into direct speech.**

0. They said they were going to the cinema.  
**"We're going to the cinema."**
1. She asked me if I'd ever been to Paris.  
" \_\_\_\_\_?"

2. He told me not to leave the door open.

“ \_\_\_\_\_.”

3. She asked him if he'd look after her bags.

“ \_\_\_\_\_?”

4. They said they couldn't wait any longer.

“ \_\_\_\_\_.”

5. She said she'd bought a new burglar alarm.

“ \_\_\_\_\_.”

**XVI. Find and correct the mistakes in each sentence.**

0. He asked her bring him a sandwich.

**He asked her to bring him a sandwich.**

1. She told to him she was tired.

\_\_\_\_\_.

2. I asked him what he is crying about.

\_\_\_\_\_.

3. She asked me what did I want to watch.

\_\_\_\_\_.

4. He told that he had been to prison.

\_\_\_\_\_.

5. I apologised for eat the last sandwich.

\_\_\_\_\_.

**XVII. Complete the second sentence so that it has a similar meaning to the first sentence, using the word given. Do not change the word given. You must use between two and five words, including the word given.**

1. Somebody is coming to repair the computer the day after tomorrow.

**REPAIRED**

I **AM HAVING THE COMPUTER REPAIRED** the day after tomorrow.

2. Mary studied a lot. She wanted to pass the exam.

**VIEW**

Mary studied a lot with \_\_\_\_\_ the exam.

3. That's the most stupid excuse I've ever heard.

**SUCH**

I've never \_\_\_\_\_ excuse.

4. Please don't go to that conference next week.

**RATHER**

I'd \_\_\_\_\_ to that conference next week.

5. Even though he tried hard, he couldn't do anything about it.

**MATTER**

No \_\_\_\_\_ tried, he couldn't do anything about it.

6. What's the depth of the lake?' Martha asked her mother.

**HOW**

Martha asked her mother \_\_\_\_\_ was.

## FRIDAY

XVIII. Read the story. Then answer the questions below.

### "Tattoo"

Justin's mom had set down the house rules with aplomb. Only the most **obtuse** person would have failed to understand: no tattoos, no body piercings, and no co-ed sleepovers while living in the house of Elaine Tucker Brown.

Still, the day Justin turned 18, he lied to his mother about where he was going and headed straight to the tattoo parlor, as if **impervious** to his mother's wrath.

He got a light blue heart the size of an orange permanently etched on his arm. Above this work of art was the word "Blessed."

No, Justin was not stupid, but he was obstinate.

Elaine saw this as an act of sheer defiance. She was incensed, her anger **exacerbated** by the fact that Justin had breezed into the house, found her in the kitchen, taken off his shirt with a smile, and said, "Got it!"

"No, Justin. Let me tell you what you've got," Elaine said angrily. "You've got five minutes to go upstairs and pack a bag. I'm taking you to Pop-Pop's."

The ride to Pop-Pop's house was chilly, to say the least. Elaine berated Justin for everything she could think of, which wasn't much because he was a straight-A senior with a full academic scholarship to his top college pick. He had a kind heart and had started a foundation in the ninth grade, which donated used sporting equipment to underprivileged kids in South Africa.

Elaine pulled up to her father's door and ordered Justin out. Not 10 minutes later, her cell phone rang.



“Elaine, have you lost it? You are kicking a boy who is as good as him out of the house for a tattoo – that says ‘Blessed,’ no less?” her father asked, incredulous. “You will miss him so much. Don’t cut off your nose to spite your face, Elaine.

Come pick this young man up.”

Elaine, having grown up obeying most of her parents’ demands, turned her car around and went back to pick up her son. Justin was surprisingly **contrite**. “Sorry for being so disrespectful, Mom,” he said earnestly. “I will try to follow house rules from now on.”

**1. What other title would best fit this passage?**

- A. “House Rules”
- B. “Visiting Pop-Pop”
- C. "Straight A's"
- D. “Body Piercings”

**2. As used in paragraph 1, which is the best antonym for obtuse?**

- A. foolhardy
- B. intelligent
- C. passionate
- D. stubborn

**3. Which of the following proverbs does Elaine seem to learn by the end of the story?**

- A. much ado about nothing
- B. familiarity breeds contempt
- C. no arguments will give courage to the coward
- D. if words suffice not, blows must follow

**4. Which of the following proverbs does Justin seem to learn by the end of the story?**

- A. look before you leap
- B. pleasure bought with pain hurts
- C. youth’s first duty is reverence to parents
- D. if men had all they wished, they would often be ruined

**5. In the final paragraph, the author writes, "Justin was surprisingly contrite." Which of the following is the best way to rewrite the above sentence while keeping its original meaning the same?**

- A. Justin was surprisingly relaxed.
- B. Justin was surprisingly remorseful.
- C. Justin had surprisingly lost his bad attitude.
- D. Justin had surprisingly become somber.

6. What was Justin's attitude when he showed his mother the tattoo?
- A. wilfully defiant
  - B. cautiously jubilant
  - C. convincingly contrite
  - D. obviously melodramatic
7. As used in paragraph 2, which is the best antonym for impervious?
- A. elated
  - B. impenetrable
  - C. invigorated
  - D. vulnerable
8. As used in paragraph 4, which is the best antonym for exacerbated?
- A. intensified
  - B. evened
  - C. extinguished
  - D. decreased
9. "You are kicking a boy as good as him out of the house for a tattoo – that says 'Blessed,' no less?"  
The above sentence from the story has a grammatical error. Which of the following correctly identifies this error?
- A. good should be well
  - B. him should be he
  - C. 'Blessed,' should be "Blessed,"
  - D. less should be lest
10. Using the passage as a guide, which is the best interpretation of the idiom, "cut off your nose to spite your face," as used in paragraph 8?
- A. calling something bad that is not
  - B. trying to teach something too difficult
  - C. loving a person less for what he has done
  - D. pursuing revenge and hurting yourself in the process



## WEEK 4

### MONDAY

#### I. Circle the correct words.

I bought a pair of shoes from the new shop in town six months ago. They were on (0) offer / refund. The original price was £60, but they were selling for £45 – that's 25% (1)

**worth / off** – and you know I love a (2) **bargain / tip**. But it turned out they weren't good (3) **reward / value** for money. There's already a hole – in them, so I don't think they were (4) **owed / worth** £45. Do you think I should take them back and ask for a (5) **refund / tip**, or am I too late?

## II. Complete the conversation with the words in the list.

**finance | healthcare | education | employer | salary | qualifications**

**TOM:** Do you know what kind of job you'll want when you finish your (0) education?

**JILL:** I'm thinking about going into (1) \_\_\_\_\_. I might become a nurse? What about you?

**TOM:** Oh, I'm looking for something that pays a bigger (2) \_\_\_\_\_ than nursing! I want to get into (3) \_\_\_\_\_ and work for a bank. That's where the money is!

**JILL:** Do you need to get lots of (4) \_\_\_\_\_ for that?

**TOM:** Not really. You just have to impress your (5) \_\_\_\_\_. If you get results, you'll be rewarded.

## III. Circle the correct letter.

0.

a. I'll be ride to school at that time.

b. I'll be riding to school at that time.

1.

a. Our car will have done 50,000 km soon.

b. Our car will be doing 50,000 km soon.

2.

a. How long will you be learning English by the end of this year?

b. How long will you have been learning English by the end of this year?

3.

a. We'll be enjoying the sunshine at this time next week.

b. We'll have enjoyed the sunshine at this time next week.

4.

a. In May, Dad will have been working at this school for 12 years.

b. In May, Dad will have been worked at this school for 12 years.

5.



- a. Will you have had dinner by 8 o'clock?
- b. Will you have to had dinner by 8 o'clock?

**IV. Read the text and circle the correct answer for each number.**

**THE GIANT PANDA**

The giant panda is a beloved animal in China. It is regarded (1) ... a national (2) ... . It is found mostly in southwestern China in Sichuan, Shaanxi and Gansu provinces. The giant panda is part of the bear family. It has a white coat with black trimmings around its eyes and on its ears, arms, and legs. Adult pandas can be 5 feet (1.5 meters) long and weigh (3) ... to 330 pounds (150 kilograms). The giant panda leads a (4) ... life, except during the mating season.

It lives in bamboo forests (5) ... the mountains. It can climb trees but lives mainly on the ground. (6) ... most bears, the giant panda does not hibernate. It moves to low-lying areas during the winter in search (7) ... warmer temperatures. The giant panda has a mainly (8) ... diet, eating mostly bamboo shoots and leaves. It also eats insects and small rodents. Giant panda breeding groups are small and isolated from one another.

- |                 |             |               |               |
|-----------------|-------------|---------------|---------------|
| 0. A) like      | B) as       | C) to         | D) that       |
| 1. A) fortune   | B) value    | C) treasure   | D) prize      |
| 2. A) down      | B) on       | C) up         | D) off        |
| 3. A) solitary  | B) alone    | C) friendless | D) unsociable |
| 4. A) on        | B) at       | C) under      | D) in         |
| 5. A) unlike    | B) but      | C) owing      | D) unlikely   |
| 6. A) to        | B) of       | C) for        | D) with       |
| 7. A) vegetable | B) vegetate | C) vegetarian | D) vegetation |

**TUESDAY**

**V. Put the words in order to make sentences.**

0. finished / by / 9 o'clock / have / I'll / my homework  
I'll have finished my homework by 9 o'clock.
1. have / She'll / enough / by / saved / June / money

2. this mess / We'll / sorted / before / have / the end / of the day / out

---

3. been / for / My parents / have / will / married / in June / 20 years

---

4. tomorrow / you / Will / decided / by / have ?

---

5. achieved / you / What / have / you're 30 / by the time / will ?

---

**VI. Complete the sentences with the verbs in the list. Use the future continuous or future perfect simple.**

**travel | ride | not leave | read | cook | have**

0. By tomorrow, I **'ll have been reading** this book for a month!

1. By this time next week, we \_\_\_\_\_ our bicycles in France.

2. Do you think mum \_\_\_\_\_ dinner for us by the time we get back?

3. You \_\_\_\_\_ breakfast between 8 a.m. and 9 a.m. tomorrow.

4. Come and visit me anytime tomorrow – I \_\_\_\_\_ the house all day.

5. By the end of this trip, we \_\_\_\_\_ over 5,000km.

**VII. Circle the correct form of the verb.**

0. You **'ll be spending** / **'ll have spent** all your money soon if you don't slow down!

1. Come and see me in the library, where I **'ll be studying** / **'ll have studied**.

2. We **'ll be living** / **'ll have lived** in this town for two years in January.

3. Will **you be finishing** / **you have finished** your dinner in 10 minutes time?

4. Don't call James now – he **'ll be working out** / **'ll have worked out** at the gym.

5. Sam **won't be hearing** / **won't have heard** the match result yet.

**VIII. Read the text below and think of the word which fits each gap. Use only one word in each gap.**

### THE HISTORY OF PAPER

The history of paper is also the history of human culture and (0)CIVILISATION. The Egyptians, Greeks and Romans wrote on "papyrus", a paper-like material. Today's kind of paper was first developed and used in China. Paper was the most important (1) \_\_\_\_\_ of information in the past. It was only with increasing paper production that the transfer of (2) \_\_\_\_\_, education and information to a larger portion of (3) \_\_\_\_\_ became possible.

With paper emperors were able to administrate large empires more easily. In former times paper was a (4) \_\_\_\_\_ product, and paper making an art - an art that was often kept secret because of the outstanding (5) \_\_\_\_\_ of the product. Today paper has changed from a rare artisan material to a commodity product, with a high practical value in communication, in (6) \_\_\_\_\_, artistic, hygienic, sanitary, and technical applications. Nobody can imagine a word without paper. A large variety of paper grades are produced to suit the special (7) \_\_\_\_\_ of each application.

CIVILISE

CARRY

KNOW

SOCIAL

VALUE

ADVANCE

EDUCATE

REQUIRE

## WEDNESDAY

### IX. Write the questions.

0. A: **What will you be doing at 7 a.m. tomorrow?**

B: I'll be taking a shower at 7 a.m. tomorrow.

1. A: \_\_\_\_\_ ?

B: Maria will be waiting for you when you get there.

2. A: \_\_\_\_\_ ?

B: They'll be taking a break at 1 o'clock.

3. A: \_\_\_\_\_ ?

B: No, I won't be working tomorrow.

4. A: \_\_\_\_\_ ?

B: Matt will be looking after his little sister at 8 o'clock tonight.

5. A: \_\_\_\_\_ ?

I'll be staying at my aunt's house this weekend.

**X. Complete the mini dialogues with the words in the list.**

**mind | How | awful | What | That's | sorry**

0. A: We lost nearly £100!  
B: How **awful**.
1. A: Danny didn't get the job he wanted.  
B: \_\_\_\_\_ a real shame.
2. A: My favourite football team lost again.  
B: Never \_\_\_\_\_.
3. A: My mum lost her job at the hospital.  
B: I'm really \_\_\_\_\_ to hear that.
4. A: We've already spent nearly all our holiday money!  
B: \_\_\_\_\_ a pity.
5. A: I don't think I'll ever be able to afford to buy my own flat.  
B: \_\_\_\_\_ sad.

**XI. Put the words in order to make sentences.**

0. sleeping / by / She'll / be / now  
**She'll be sleeping by now.**
1. be / football / We'll / all / playing / weekend  
\_\_\_\_\_.
2. they / have / by / Will / 6 p.m. / arrived?  
\_\_\_\_\_?
3. in / working / 10 years from now / be / I'll / a bank  
\_\_\_\_\_.
4. wearing / He'll / a red jacket / be / this evening  
\_\_\_\_\_.
5. drunk / coffees / by the end of the day / How many / you / have / will?  
\_\_\_\_\_?

**XII. Complete the second sentence so that it has a similar meaning to the first sentence, using the word given. Do not change the word given. You must use between two and five words, including the word given.**

<p>1. Tomorrow's conference is postponed and it will be held next month. <b>PUT</b></p> <p>Tomorrow's conference has <b>BEEN PUT OFF</b> until next month.</p>
--

<p>2. She prefers watching TV to reading books. <b>RATHER</b></p> <p>She _____ read books.</p>
<p>3. In his opinion, these two kinds of art are totally different from each other. <b>COMPARISON</b></p> <p>In his opinion, there is _____ these two kinds of art.</p>
<p>4. 'What do you think of the new health centre?' <b>ASKED</b></p> <p>She _____ of the new health centre.</p>
<p>5. Fiona doesn't like bananas. She doesn't like grapes either. <b>NOR</b></p> <p>Fiona likes _____ grapes.</p>
<p>6. It's believed that he was the most handsome boy in our school. <b>TO</b></p> <p>He is _____ the most handsome boy in our school.</p>

**THURSDAY**

**XIII. Find and correct the mistakes in each sentence.**

0. She'll has written three books by the end of 2020.

She'll have written three books by the end of 2020.

1. I'll having another piano lesson at the same time next week.

\_\_\_\_\_

2. He'll soon have earning enough money to buy a new laptop.

\_\_\_\_\_

3. How many classes will you be to by the end of today?

\_\_\_\_\_

4. By that time, I'll be lived in my first apartment.

\_\_\_\_\_

5. Will you be learned how to drive by the time you're 19?

\_\_\_\_\_

**XIV. Complete the conversation. Use the future continuous form of the verb in brackets.**

**NICK:** Do you want to come out tonight?

**JULIE:** No, sorry. I (0) 'll be studying (study) until I go to bed.

**NICK:** What about tomorrow? (1) \_\_\_\_\_ (you / study) then?

**JULIE:** No.

**NICK:** Great. I (2) \_\_\_\_\_ (wait) for you outside school at 7 p.m. OK?

**JULIE:** No. I said I (3) \_\_\_\_\_ (not study), but I (4) \_\_\_\_\_ (do) something else.

**NICK:** What (5) \_\_\_\_\_ (you / do)?

**JULIE:** I don't know yet.



**XV. Answer the questions. Use your own ideas.**

0. What will you be doing at this time tomorrow?

I 'll be sitting in this classroom.

1. What will you be doing at 11 a.m. on Saturday?

\_\_\_\_\_

2. How long will you have been learning English by the end of this year?

\_\_\_\_\_

3. How many English exercises will you have done by the end of today?

\_\_\_\_\_

4. Will you be sleeping at 11 p.m. tonight?

\_\_\_\_\_

5. Will you have left school by the time you are 16?

\_\_\_\_\_

**XVI. For questions 1-7, read the text below and think of the word which fits each gap. Use only one word in each gap.**

**ALASKA: IT'S A STATE OF MIND**

One of the greatest things about Alaska is (0) THAT it takes the term casual to new heights. While the state has highly cultivated enclaves, (1) \_\_\_\_\_ as Anchorage, Alaska's largest city, and Juneau, the state capital (population 31,000), for the most part Alaskans are down-to-earth people. They're friendly bunch, more comfortable in Carhartts and cutoffs (2) \_\_\_\_\_ cashmere and corduroy. The arts thrive, not only in the larger cities (3) \_\_\_\_\_ also in the small towns. In their own strong spirited way.

Alaskans embrace their independence and refuse (4) \_\_\_\_\_ be stereotyped. They'll have a sold-out opera, but only half will dress (5) \_\_\_\_\_. There (6) \_\_\_\_\_ ultra-fancy restaurants, but they'll entertain kids with smiles on their faces. For visitors, this translates into a vacation completely devoid (7) \_\_\_\_\_ stress. Wear your evening gown if you like - it doesn't matter if it's to the local ballgame or burger joint. Anything goes.

**XVII. Then answer the questions below****“Dreams”**

The relationship between my mother, sister and me had been cold and inimical for as long as I could remember.

To me, my mother was irrational, hurling hurtful invectives for the slightest infraction. “Don’t matter,” my mother grumbled when I asked her where she moved my watercolour paints. “It ain’t like you got talent.” The time our mailbox got knocked off she somehow got it in her head that I was the culprit. “Never respected nothin’,” I heard her say. And my sister took my mother’s side against me every time. Five years my senior, Tammy seemed not to have a brain in her head. She dithered about everything, incapable of making any firm decision. No matter how often my mother deprecated her— “dumb, ugly, fat”—Tammy made futile attempts to fawn her way back into mother’s good graces.

My father would pontificate, “You three are more alike than you know.”

In April of 2000, my mother kicked us both out of the house. (Dad had been exiled many years before.) After that, my sister and I went our separate ways. It was then that I began having recurring dreams.

In one, I am running to catch up with a woman. Each time I get near, I trip and fall. Another woman, smiling and shouting my name, comes with great alacrity and offers her hand, but when I reach to grab it, she disappears.

In another, a female professor hands me a test. Although I have spent hours studying for it, I know none of the answers. The professor derides me for my poor performance. I watch while she relays my ignorance to the class with comic hilarity.

These dreams were not hard to understand. In fact, it was just the opposite; they were pellucid, and absent any knowledge of dream interpretation, I was still able to devise their significance. I knew that they both reflected the pugnacious relationship I shared with my mother and sister.

However, there was one dream I could never quite construe. I bite into an apple. All my teeth fall out. I had this dream far more than any of the others.

Years later, in an effort to heal our fractious relationship, Mom, Tammy and I elected to go to counselling together. After several sessions, I told my dream about teeth tumbling out of my head.

“My God, Crystal,” said my mother. “I’ve had the exact same dream many times.” “Me, too,” said Tammy solemnly.

Breakthrough? No idea. But I was reminded of the words of my now-dead father. Maybe the three of us are more alike than we know.

**1. Which is most likely to make a relationship inimical (paragraph 1)?**

- A. great pathos
- B. frequent maledictions
- C. magnanimous gestures
- D. ingenious discussions
- E. heated debates

**2. As used in paragraph 2, which is the best synonym for invectives?**

- A. insults
- B. names
- C. profanity
- D. words
- E. misfortunes

**3. If the story were true, which would best describe its genre?**

- A. literary essay, based on a piece of literature
- B. memoir essay, centered on a significant memory from the past
- C. persuasive essay, characterized by choosing a side and refuting other arguments
- D. expository essay, meant to inform the reader of a body of knowledge
- E. satire, in which human folly and vice are held up to scorn, derision, or ridicule

**4. How does the relationship between the narrator, her mother, and her sister seem to change from the beginning of passage to end?**

- A. from brusque to florid
- B. from egregious to impassive
- C. from enervating to rejuvenating
- D. from destructive to collaborative
- E. from convivial to estranged

**5. As used in paragraph 7, which is the best antonym for pellucid?**

- A. dirty
- B. frightening
- C. enlightening
- D. strange
- E. unclear

**6. "The professor derides me for my poor performance."**

**Which of the following is the best way to rewrite the above sentence (from paragraph 7) while keeping its original meaning the same?**

- A. The professor is in disbelief due to my poor performance.
- B. The professor laughs mockingly at my poor performance.
- C. The professor announces my poor performance.
- D. The professor gives me a failing grade for my poor performance.
- E. The professor gives me a tutorial because of my poor performance.

**7. "I bite into an apple. All my teeth fall out."**

**Which of the following is the best way to rewrite the above sentences (from paragraph 9) while keeping their original meaning the same?**

- A. I bite into an apple, so all my teeth fall out.
- B. I bite into an apple, yet all my teeth fall out.
- C. I bite into an apple, and all my teeth fall out.
- D. I bite into an apple, because all my teeth fall out.



E. I bite into an apple, but all my teeth fall out.

**8. If the professor in the narrator's dream (paragraph 7) represented someone in her life, who would that person most likely be, and why?**

- A. the sister, because she was described in the passage as dithering
- B. the mother, because she was described in the passage as mean-spirited
- C. the narrator, because she seems to be testing everyone in the passage
- D. the father, because he understood that that the three women were alike
- E. herself, **because** she was hyper-aware of her own problems



## Inventario de ejercicios, problemas y actividades de Educación Física (tercero grado de secundaria) (Apoyo a la recuperación académica 2017)





Estimado estudiante:







Te proponemos el presente inventario de ejercicios y actividades como un recurso de apoyo para el proceso de recuperación académica que debes seguir durante el mes de enero de 2018. Te pedimos tener presente que:

- El inventario ha sido elaborado de acuerdo con la problemática existente en nuestra población estudiantil.
- El inventario ha sido dosificado para ser desarrollado en cuatro semanas, de lunes a viernes, destinando para ello una hora diaria aproximadamente. Es importante que anotes tus resultados en la tabla de control del rendimiento físico. Al final del documento se te presenta una tabla para que obtengas tus puntajes.
- El inventario debe ser desarrollado bajo la supervisión del padre de familia.
- En la tabla de control diario, el padre de familia debe firmar para apoyar y controlar el avance diario del estudiante en el desarrollo del inventario.
- No hemos incluido una calendarización específica para el desarrollo del inventario (fechas de inicio y fin), asumiendo que cada estudiante lo hará en coordinación con sus padres, considerando la realidad particular y los planes de la familia. En todo caso, el trabajo ha sido previsto para cuatro semanas.

### Semana 1

**Las actividades físicas y deportivas se recomienda que se realicen tres veces por semana, descansando los domingo que son de esparcimiento familiar.**









Competencia	Criterios	Tiempo	Ejercicios y actividades	Referencia
Asume una vida saludable.	Alimentación saludable	Antes y después de cualquier actividad física	<ul style="list-style-type: none"> <li>- Consumo de agua</li> <li>- Consumo de fruta</li> <li>- Uso de polo auxiliar</li> <li>- Aseo personal</li> <li>- Uso de bloqueador si está expuesto al Sol</li> </ul>	
		20'	<p><b>Información</b></p> <p>¿Por qué debemos desayunar bien?</p> <p>El desayuno es la primera comida después del ayuno nocturno y afecta de diversas maneras a nuestro organismo:</p> <ul style="list-style-type: none"> <li>- Nos aporta energía para todo el día, en especial para la mañana.</li> <li>- Condiciona nuestro estado de ánimo.</li> <li>- Incide en el rendimiento físico y mental.</li> <li>- Nos permite comer menos cantidad a lo largo del día, ya que nuestro cuerpo no detecta carencias.</li> <li>- Nuestro cuerpo asimila mejor los alimentos que tomamos en ayunas.</li> </ul>	
	Calentamiento	4'	<ul style="list-style-type: none"> <li>- El estudiante realiza movimiento articular 2 s.</li> <li>- Estiramiento en los diferentes segmentos del cuerpo 2 s.</li> </ul>	
		5'	Comienza realizando 12 repeticiones de sentadillas prisionero (con las manos tras la nuca).	

		5'	Realiza 10 repeticiones de splits con salto (salto con una pierna hacia delante).	
		5'	65 repeticiones de saltos Jack o polichinelas (saltos abriendo y cerrando las piernas mientras abres y cierras los brazos por encima de la cabeza con palmada).	
	Preparación física (resistencia aeróbica)	20'	<b>Sistema de entrenamiento interval training</b> El estudiante tiene que trotar de forma continua por espacio de 2'30" con su propio paso y esfuerzo con un descanso de 1' caminando. Al termino del descanso vuelve a trotar y seguir la secuencia sugerida, se repite la acción por 5 series continuas.	
	Preparación física (fuerza muscular)	10'	El estudiante tiene que realizar <b>fuerza de brazos</b> en la posición de planchas, 3 series de 10 repeticiones. Descanso de 1'30" después de cada serie.	
		10'	El estudiante tiene que realizar <b>fuerza abdominal</b> en la posición clásica con rodillas flexionadas y manos detrás del pabellón de la oreja, su ejecución es de 30" en la cual se debe ejecutar mínimo 20 abdominales cruzados. Descanso después de una serie de 1'30". Este trabajo en su primera semana tiene 3 series bien ejecutadas	
Se desenvuelve de manera autónoma a través de su motricidad.	Preparación técnica y física	60'	<b>Recomendación</b> Los deportes a practicar en verano quedan a libre voluntad del estudiante (fútbol, basquetbol, voleibol, natación, etc.). Si crees conveniente en algún taller o academia deportiva de tu agrado.	
Interactúa a través de sus habilidades sociomotrices.	Preparación de estrategias y tácticas deportivas (trabajo en equipo)	60'	<b>Recomendación</b> El estudiante debe en estas vacaciones ser parte de una agrupación donde se practique algún tipo de deporte de forma competitiva o en la zona donde reside ser parte de un grupo que ejecute acciones de apoyo a la comunidad donde él aplique estrategias y tácticas para el logro de un objetivo común en la práctica de diferentes actividades físicas.	

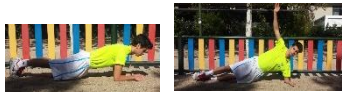
**Tabla de control del rendimiento físico de la semana 1**

Control semanal	Fuerza de brazos en 30"	Fuerza abdominal en 30"	Fuerza de piernas (Salto largo sin carrera)	Velocidad (50 m)	Resistencia/Intervalos
Cantidad/distancia tiempo					
Puntaje (Guíate de la tabla anexa)					
Firma					

Las actividades físicas y deportivas se recomienda que se realicen tres veces por semana, descansando los domingo que son de esparcimiento familiar.

Competencia	Capacidades	Tiempo	Ejercicios y actividades	
Asume una vida saludable.	Alimentación saludable	20'	<p><b>Información</b></p> <p><b>El almuerzo</b></p> <p>El almuerzo es una comida diaria muy importante y además de gran relevancia cultural, gracias a ese pequeño descanso podemos comer algo para reponer energías, porque desde el desayuno no se han ingerido más alimentos y con el paso de las horas el cuerpo necesita más energía para afrontar de forma satisfactoria las actividades que se vayan a realizar, en el caso de los niños, les ayudará tanto físicamente como mentalmente durante el horario escolar.</p>	
	Calentamiento	4'	<ul style="list-style-type: none"> <li>- El estudiante realiza movimiento articular 2'.</li> <li>- Estiramiento en los diferentes segmentos del cuerpo 2'</li> </ul>	
		5'	8 repeticiones de burpee (De pie, nos aguachamos a tocar el suelo con las manos, echamos las piernas atrás, realizamos un fondo y nos levantamos para dar un salto).	
		5'	30 segundos de abdominales oblicuos plank para cada lado.	
		5'	65 repeticiones de saltos Jack o polichinelas (saltos abriendo y cerrando las piernas mientras abres y cierras los brazos por encima de la cabeza con palmada).	
	Preparación física (velocidad)	10'	El estudiante inicia en cualquiera de los conos realizando diagonales, laterales y carreras de espalda a velocidad y con cambios de ritmo.	
	Preparación física (resistencia aeróbica)	20'	<p><b>Sistema de entrenamiento interval training</b></p> <p>El estudiante tiene que trotar de forma continua por espacio de 2'30" con su propio paso y esfuerzo con un descanso de 1' caminando. Al termino del descanso vuelve a trotar y seguir la secuencia sugerida, se repite la acción por 5 series continuas.</p>	
	Preparación física (fuerza muscular)	10'	<ul style="list-style-type: none"> <li>- 8 repeticiones de dominadas con agarre hacia adentro</li> <li>- 3 series</li> </ul>	
10'		<ul style="list-style-type: none"> <li>- 10 repeticiones de abdominal puente</li> <li>- 3 series</li> </ul>		
Se desenvuelve de manera autónoma a través de su motricidad.	Preparación técnica y física	60'	<p><b>Recomendación</b></p> <p>Los deportes a practicar en verano quedan a libre voluntad del estudiante (fútbol, basquetbol, voleibol, natación, etc.). Si crees conveniente en algún taller o academia deportiva de tu agrado.</p>	



Interactúa a través de sus habilidades sociomotrices.	Preparación de estrategias y tácticas deportivas (trabajo en equipo)	60'	<b>Recomendación</b> El estudiante debe en estas vacaciones ser parte de una agrupación donde se practique algún tipo de deporte de forma competitiva o en la zona donde reside ser parte de un grupo que ejecute acciones de apoyo a la comunidad donde él aplique estrategias y tácticas para el logro de un objetivo común en la práctica de diferentes actividades físicas.	
---	--	-----	--	--

**Tabla de control del rendimiento físico de la semana 2**









Control semanal	Fuerza de brazos en 30"	Fuerza abdominal en 30"	Fuerza de piernas (Salto largo sin carrera)	Velocidad (50 m)	Resistencia/Intervalos
Cantidad/distancia tiempo					
Puntaje (Guíate de la tabla anexa)					
Firma					

### Semana 3

Las actividades físicas y deportivas se recomienda que se realicen tres veces por semana, descansando los domingos que son de esparcimiento familiar.

Competencia	Capacidades	Tiempo	Ejercicios y actividades	
Asume una vida saludable.	Alimentación saludable	20'	<b>Información</b> <b>Beneficios y perjuicios de la cena</b> La cena es la última comida del día, y su función es la de acostarnos con el estómago vacío y contribuir a un buen descanso, pero sin embargo no debe ser una cena tan nutritiva como el desayuno o el almuerzo, ya que apenas vamos a gastar energía durante la noche. Por eso es importante que hagamos la cena temprana o bien ligera. Cuando cenamos de manera copiosa, demasiado tarde, o incluyendo alimentos poco saludables, podemos notar algunos de los siguientes efectos en nuestra salud: <ul style="list-style-type: none"> <li>- Insomnio, falta de descanso y cansancio por la mañana</li> <li>- Aspecto ojeroso y apagado en el rostro</li> <li>- Retención de líquidos</li> <li>- Estreñimiento</li> <li>- Mucosidades al despertar</li> <li>- Problemas hepáticos y malas digestiones, con acidez, flatulencias, etc.</li> <li>- A la larga, sobrepeso o falta de peso</li> </ul>	
		4'	<b>Ejercicios de movilidad para el cuello</b> -Inclina la cabeza hacia la izquierda y sujétala con una mano, baja el hombro derecho. Cuenta hasta diez. Realiza el mismo ejercicio hacia el otro lado, repitiendo 3 veces cada lado. -Gira la cabeza hacia ambos lados procurando que la barbilla se toque con el hombro correspondiente. -Gira la cabeza en el sentido de las agujas del reloj, despacio y con movimiento suave, para impedir posibles mareos y contracturas.	
	5'	- 8 repeticiones de burpee. (De pie, nos aguachamos a tocar el suelo con las manos, echamos las piernas atrás, realizamos un fondo y nos levantamos para dar un salto).		









		5'	30 segundos de abdominales oblicuos plank para cada lado.	
		5'	65 repeticiones de saltos Jack o polichinelas ( <b>saltos abriendo y cerrando las piernas mientras abres y cierras los brazos por encima de la cabeza con palmada</b> ).	
	Preparación física (velocidad)	10'	El estudiante inicia en cualquiera de los conos realizando diagonales, laterales y carreras de espalda a velocidad y con cambios de ritmo.	
	Preparación física (resistencia aeróbica)	20'	<b>Sistema de entrenamiento interval training</b> El estudiante tiene que trotar de forma continua por espacio de 2'30" con su propio paso y esfuerzo con un descanso de 1' caminando. Al termino del descanso vuelve a trotar y seguir la secuencia sugerida, se repite la acción por 5 series continuas.	
	Preparación física (fuerza muscular)	10'	8 repeticiones de <b>dominadas con agarre</b> hacia adentro. 3 series	
		10'	10 repeticiones de abdominal puente. 3 series.	
Se desenvuelve de manera autónoma a través de su motricidad.	Preparación técnica y física	60'	<b>Recomendación</b> Los deportes a practicar en verano quedan a libre voluntad del estudiante (fútbol, basquetbol, voleibol, natación, etc.). Si crees conveniente en algún taller o academia deportiva de tu agrado.	
Interactúa a través de sus habilidades sociomotrices.	Preparación de estrategias y tácticas deportivas (trabajo en equipo)	60'	<b>Recomendación</b> El estudiante debe en estas vacaciones ser parte de una agrupación donde se practique algún tipo de deporte de forma competitiva o en la zona donde reside ser parte de un grupo que ejecute acciones de apoyo a la comunidad donde él aplique estrategias y tácticas para el logro de un objetivo común en la práctica de diferentes actividades físicas.	

**Tabla de control del rendimiento físico de la semana 3**

Control semanal	Fuerza de brazos en 30"	Fuerza abdominal en 30"	Fuerza de piernas (Salto largo sin carrera)	Velocidad (50 m)	Resistencia/Intervalos
Cantidad/distancia tiempo					
Puntaje (Guíate de la tabla anexa)					
Firma					

**Las actividades físicas y deportivas se recomienda que se realicen tres veces por semana, descansando los domingo que son de esparcimiento familiar**

Competencia	Capacidades	Tiempo	Ejercicios y actividades		Firma
Asume una vida saludable.	Alimentación saludable	Durante el día	<p><b>Información</b>  <b>5 comidas al día</b>            Cinco comidas al día nos ayudarán a mantener mejor nuestro régimen, básicamente por una serie de factores:</p> <p>1) Logran que nuestro metabolismo no retenga tan fácilmente las grasas. Cuando pasamos muchas horas sin comer, el sistema digestivo activa un mecanismo de autoprotección consistente en retener grasas para intentar, de ese modo, asegurarse el alimento ante una previsible, fase de carestía. Comiendo a menudo desactivamos esa "fase de emergencia", por lo tanto, retenemos menos grasas.</p> <p>2) La sensación de hambre disminuye porque, lógicamente, hemos ingerido más alimentos. Eso nos hará comer con menos ansiedad y en menor cantidad cada vez que consumamos algún alimento</p> <p>3) El hecho de que comamos cinco veces al día elimina la posibilidad del famoso "picoteo" entre horas, lo cual nos evitará, con casi toda seguridad, el que ingiramos los alimentos "chatarra" tan desaconsejables.</p>		
	Calentamiento	4'	<p><b>Ejercicios de movilidad para el tobillo</b>            Coloca el pie en una posición que pueda marcar un ángulo de 90 grados con la pierna. El dorso de tu pie debe de quedar frente a ti. Mantén la rodilla recta por lo menos 10 segundos y regresa a la posición neutral. Repite los pasos anteriores 10 veces.</p> <p>Como regla general, ten en cuenta que el ejercicio se prolonga hasta que sientas un calor localizado muy intenso en la zona que trabajas, y hasta cierta fatiga de los músculos implicados en el movimiento. Como regla general trabaja de arriba hacia abajo, es decir del cuello a los tobillos, y siempre antes de esfuerzos que impliquen movimientos explosivos o a gran velocidad.</p>		
		5'	8 repeticiones de burpee. (De pie, nos aguachamos a tocar el suelo con las manos, echamos las piernas atrás, realizamos un fondo y nos levantamos para dar un salto).		
		5'	30 segundos de abdominales oblicuos plank para cada lado.		
		5'	65 repeticiones de saltos Jack o polichinelas ( <b>saltos abriendo y cerrando las piernas mientras abres y cierras los brazos por encima de la cabeza con palmada</b> ).		
	Preparación física (velocidad)	10'	<p><b>El entrenamiento de la velocidad</b>            Es imprescindible hacerlo al 100% de tu capacidad. Es decir, debes ejercitarte a la mayor velocidad posible, de lo contrario no podrías estimular esta capacidad condicionante.</p> <p>Por la gran intensidad de trabajo que despliegas, los ejercicios para ganar velocidad se limitan a unos pocos segundos (hasta 8-10 segundos como límite) y los tiempos de recuperación son completos (3 minutos como mínimo)</p>		







	Preparación física (resistencia aeróbica)	20'	<b>Sistema de entrenamiento interval training</b> El estudiante tiene que trotar de forma continua por espacio de 2'30" con su propio paso y esfuerzo con un descanso de 1' caminando. Al término del descanso vuelve a trotar y seguir la secuencia sugerida, se repite la acción por 5 series continuas.		
	Preparación física (fuerza muscular)	10'	<b>Fuerza para brazos para potenciar los tríceps</b> Necesitarás la ayuda de un banco fijo que esté a la altura de tus rodillas, aproximadamente. Colócate de la forma que ves en la imagen. El ejercicio consiste en estirar y flexionar los brazos, de modo que tengan que soportar todo el peso de tu cuerpo durante la ejecución. Haz 3 series con 10 repeticiones.		
		10'	<b>Abdominales marcados</b> Tenemos que remarcar que para poder tener unos resultados visibles es imprescindible que seas constante y que cuides tu alimentación pues, una de las claves que existen para poder tener las abdominales marcadas, es eliminar la grasa de tu cuerpo y esto tan solo se consigue con una alimentación saludable y la práctica de ejercicio físico. En esta posición deberás elevar ligeramente las piernas procurando mantener el cuerpo completamente recto y tendrás que ir moviendo las piernas, una por debajo de la otra y viceversa, para hacer este ejercicio. Aguanta 30 segundos haciendo este ejercicio y, después, descansa otros 20.	<p>1.</p>  <p>2.</p> 	
Se desenvuelve de manera autónoma a través de su motricidad.	Preparación técnica y física	60'	<b>Recomendación</b> Los deportes a practicar en verano quedan a libre voluntad del estudiante (fútbol, basquetbol, voleibol, natación, etc.). Si crees conveniente en algún taller o academia deportiva de tu agrado.		
Interactúa a través de sus habilidades sociomotrices.	Preparación de estrategias y tácticas deportivas (trabajo en equipo)	60'	<b>Recomendación</b> El estudiante debe en estas vacaciones ser parte de una agrupación donde se practique algún tipo de deporte de forma competitiva o en la zona donde reside ser parte de un grupo que ejecute acciones de apoyo a la comunidad donde él aplique estrategias y tácticas para el logro de un objetivo común en la práctica de diferentes actividades físicas.		

Tabla de control del rendimiento físico de la semana 4					
Control semanal	Fuerza de brazos en 30"	Fuerza abdominal en 30"	Fuerza de piernas (Salto largo sin carrera)	Velocidad (50 m)	Resistencia/Intervalos
Cantidad/distancia tiempo					
Puntaje (Guíate de la tabla anexa)					
Firma					

Juan Carlos Pérez Sánchez  
Prof. Educación Física

Alejandro Enrique Cipriano Navarrete  
Prof. Educación Física



**TABLA ANEXA**

**EVALUACIÓN DE RENDIMIENTO FÍSICO**

**14 Y 15 AÑOS**

NIVEL DE LOGRO	PUNTOS	BRAZOS		ABDOMINALES		PIERNAS		VELOCIDAD (SEG)		RESISTENCIA (MIN)	
		BRAZOS (30 SEG) 10 PTOS	BRAZOS (30 SEG) 10 PTOS	ABDOMINALES (30 SEG) 10 PTOS	ABDOMINALES (30 SEG) 10 PTOS	PIERNAS SALTO LARGO SIN IMPULSO 10 PTOS	PIERNAS SALTO LARGO SIN IMPULSO 10 PTOS	50 METROS PLANOS PARTIDA ALTA 10 PTOS	50 METROS PLANOS PARTIDA ALTA 10 PTOS	1000 m VARONES 10 PUNTOS	800 m DAMAS 10 PUNTOS
<b>E</b>	<b>10</b>	26 o +	26 o +	34 o +	26 o +	1,90 m	1,65 m	7,2	8,0	3,50	4,00
<b>B</b>	<b>9</b>	23	23	30	23	1,80	1,60	7,7	8,6	4,10	4,20
	<b>8</b>	20	20	28	20	1,70	1,50	8,0	9,3	4,20	4,40
<b>R</b>	<b>7</b>	18	18	25	18	1,60	1,40	8,3	9,7	4,30	5,00
	<b>6</b>	16	16	23	16	1,50	1,30	8,5	10,0	4,45	5,10
	<b>5</b>	14	14	20	14	1,40	1,20	8,8	10,4	4,50	5,20
<b>D</b>	<b>4</b>	12	12	18	12	1,35	1,15	9,0	10,8	5,00	5,30
	<b>3</b>	10	10	16	10	1,30	1,10	9,3	11,0	5,10	5,40
	<b>2</b>	8	8	14	8	1,25	1,05	9,6	11,4	5,20	5,50
	<b>1</b>	6	6	12	6	1,20	1,00	9,9	11,8	5,40	6,10
	<b>0</b>	N/P	N/P	N/P	N/P	N/P	N/P	N/P	N/P	N/P	N/P
		M	F	M	F	M	F	M	F	M	F



## Inventario de ejercicios, problemas y actividades de Arte (tercer grado de secundaria) (Apoyo a la recuperación académica 2017)

Estimado estudiante:

Te proponemos el presente inventario de ejercicios prácticos, como un recurso de apoyo para el proceso de recuperación académica que debes seguir durante el mes de enero de 2018. Te pedimos tener presente, respecto al inventario, lo siguiente:

- Ha sido elaborado de acuerdo con los temarios de las evaluaciones de salida.
- Los ejercicios prácticos que se presentan en él han sido tomados de los documentos de trabajo del año escolar 2017 y de otras fuentes, pero que se ajustan a los contenidos del temario.
- Ha sido dosificado para ser desarrollado en cuatro semanas, de lunes a viernes, destinando para ello una hora diaria aproximadamente.
- Deben ser desarrollados en papel bond A4 blanco. Su presentación será en un fólter manila tamaño A4 (incluir carátula), el mismo que será revisado y evaluado por el docente responsables de la evaluación de recuperación, asignándole un peso de 25 % en el resultado final de la recuperación como "evaluación de portafolio". De hecho, si no lo presentas desarrollado, se te asignará la nota mínima en evaluación de portafolio.
- Si los estudiantes requiriesen presentarse a la segunda oportunidad, podrán mejorar y volver a presentarlo desarrollado, prevaleciendo, en este caso, la segunda calificación. Si no lo hiciesen, mantendrán la calificación obtenida en la primera ocasión.
- En la tabla de control diario, el padre de familia debe firmar para apoyar y controlar el avance diario del estudiante en su desarrollo.
- No hemos incluido una calendarización específica para su desarrollo (fechas de inicio y fin), asumiendo que cada estudiante lo hará en coordinación con sus padres, considerando la realidad particular y los planes de la familia. En todo caso, el trabajo ha sido previsto para cuatro semanas.
- La primera oportunidad de evaluación será a fines de enero. La presentación del portafolio (inventario desarrollado) es obligatoria desde la primera oportunidad de evaluación.

### Semana 1

#### Tema 1: Dibujo artístico: (técnica del lápiz carboncillo).

- Imprime la lámina del **anexo 1**. A continuación, dibuja el diseño propuesto. No olvides de leer las recomendaciones.

Tabla de firmas del padre de familia de control diario de la semana 1				
	Martes 2 de enero	Miércoles 3 de enero	Jueves 4 de enero	Viernes 5 de enero

### Semana 2

#### Tema 2: Dibujo artístico: (técnica de los lápices de color).

- Imprime la lámina del **anexo 2**. A continuación, dibuja el diseño propuesto. No olvides de leer las recomendaciones.

Tabla de firmas del padre de familia de control diario de la semana 1				
	Martes 2 de enero	Miércoles 3 de enero	Jueves 4 de enero	Viernes 5 de enero

**Semana 3****Tema 3 Dibujo técnico: Diseño gráfico con escuadras y compás**

- Imprime las láminas de los **anexos 3 y 4**. A continuación, dibuja el diseño propuesto. No olvides de leer las recomendaciones.

Tabla de firmas del padre de familia de control diario de la semana 1				
	Martes 2 de enero	Miércoles 3 de enero	Jueves 4 de enero	Viernes 5 de enero

**Semana 4****Tema 4: Dibujo Técnico: isometría**

- Imprime las láminas de los **anexos 5 y 6**. A continuación, dibuja el diseño propuesto. No olvides de leer las recomendaciones.

Tabla de firmas del padre de familia de control diario de la semana 1				
	Martes 2 de enero	Miércoles 3 de enero	Jueves 4 de enero	Viernes 5 de enero

Tabla de puntajes						
Semana 1		Semana 2		Semana 3	Semana 4	Puntaje
Lámina 1	Lámina 2	Lámina 3	Lámina 4	Lámina 5	Lámina 6	
3 puntos	3 puntos	3 puntos	3 puntos	4 puntos	4 puntos	

**Detalles**

Dibujo técnico	
Puntaje	Detalle
3 puntos	Lámina totalmente concluida de acuerdo al requerimiento propuesto.
2 puntos	Lámina con más del 50 % concluida de acuerdo al requerimiento propuesto.
1 punto	Lámina con menos del 50 % concluida de acuerdo al requerimiento propuesto.
0 punto	No presentó su lámina.

<b>Dibujo artístico</b>	
<b>Puntaje</b>	<b>Detalle</b>
<b>4 puntos</b>	Lámina totalmente concluida de acuerdo al requerimiento propuesto.
<b>3 puntos</b>	Lámina con más del 75 % concluida de acuerdo al requerimiento propuesto.
<b>2 puntos</b>	Lámina con más del 50 % concluida de acuerdo al requerimiento propuesto.
<b>1 punto</b>	Lámina con menos del 50 % concluida de acuerdo al requerimiento propuesto.
<b>0 punto</b>	No presentó su lámina.

Anexo 1



Dibuja el diseño propuesto con lápiz carboncillo, tomando en cuenta encuadre, proporción y degradación.

 <p>CEP Nuestra Señora del Perpetuo Socorro <small>El estudio, tan natural como el juego y el descanso</small></p>	<p>Arte</p>	<p>Lámina n.º <b>1</b></p>	<p>Dibujado por:</p>	<p><b>Cambridge English School</b> <i>using Cambridge English exams &amp; materials</i></p>	<p>Código: <b>S3-__-__</b></p>	<p>Revisado por: <b>Enrique Parks Arellano</b></p>	<p> Pequeños detalles que nos hacen <b>mejores personas</b> <small>ACREDITACIÓN INTERNACIONAL CNEP - CCEC (2014 - 2019)</small></p>
---	-------------	--------------------------------	----------------------	---	------------------------------------	--	--

## Anexo 2



Dibuja el diseño propuesto con lápices de color, tomando en cuenta encuadre, proporción, degradación y armonía de

 <p>CEP Nuestra Señora del Perpetuo Socorro <small>El estudio, tan natural como el juego y el descanso</small></p>	<p>Arte</p>	<p>Lámina n.º <b>2</b></p>	<p>Dibujado por:</p>	<p><b>Cambridge English School</b> <i>using Cambridge English exams &amp; materials</i></p>	<p>Código: <b>S3-__-__</b></p>	<p>Revisado por: <b>Enrique Parks Arellano</b></p>	<p> Pequeños detalles que nos hacen <b>mejores personas</b> <small>ACREDITACIÓN INTERNACIONAL CNEP - CCEC (2014 - 2019)</small></p>
---	-------------	--------------------------------	----------------------	---	------------------------------------	--	--

Anexo 3

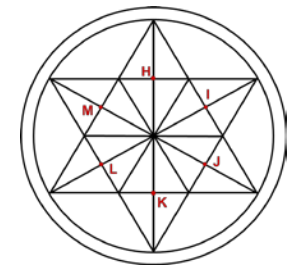
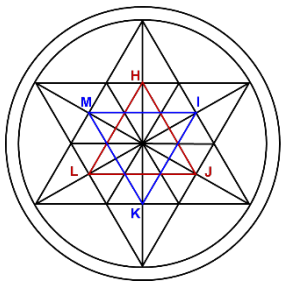
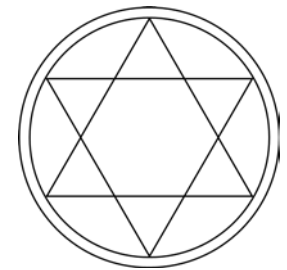
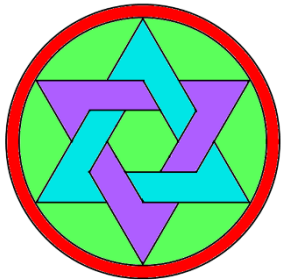
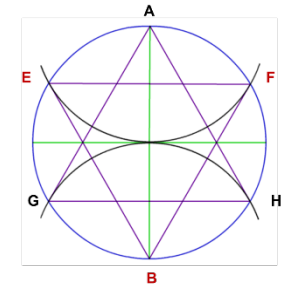
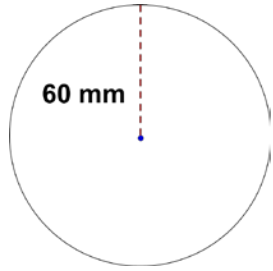

Dibuja con compás, escuadras, fine pen negro y lápices de colores el siguiente diseño gráfico.

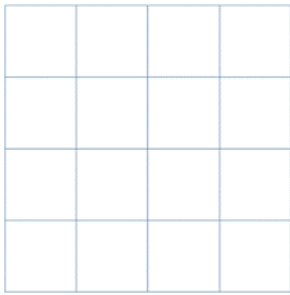

160 x 160

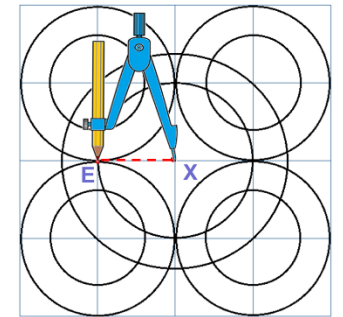
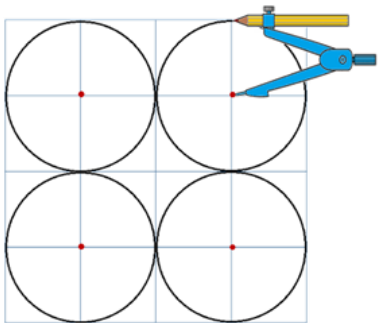
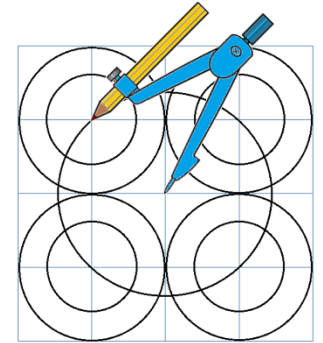

25 mm.

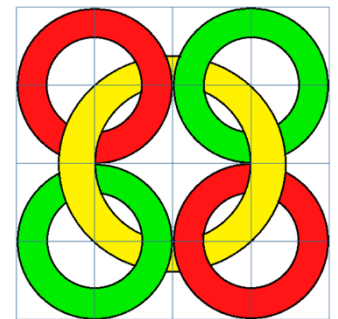
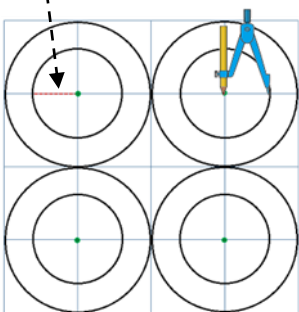

Anexo 4

Dibuja con compás, escuadras, fine pen negro y lápices de color el siguiente diseño gráfico.



Con las medidas dadas dibuja con escuadras, fine pen negro y colores los dos sólidos isométricos.

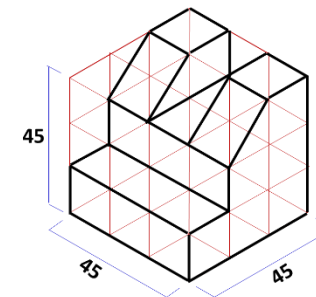
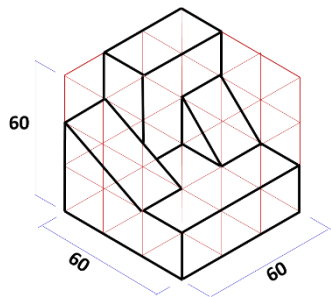

Anexo 5

Con las medidas dadas dibuja con escuadras, fine pen negro y colores los dos sólidos isométricos.

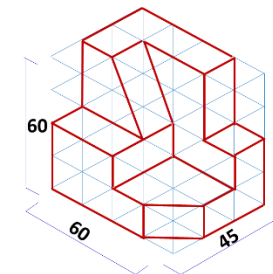
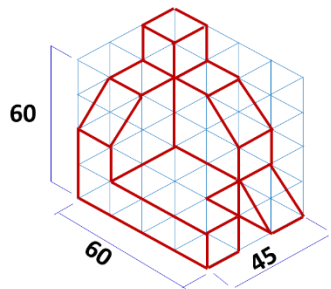

Anexo 6